

## ADB™ Mouse/Trackball Controller I.C.\*

### FEATURES

- Single-chip supporting Apple® Desktop Bus Mouse or trackball controller
- Built in collision detection so that multiple devices may be connected to the host interface without conflict
- Strobed motion encoders for reduced system power consumption
- Proprietary anti-jitter algorithm simplifies motion encoder interface
- Motion sampling rate of 6000 samples/second
- Available In:
  - 18-lead 300 mil PDIP
  - 18-lead 300 mil SOIC
  - 20-lead 209 mil SSOP

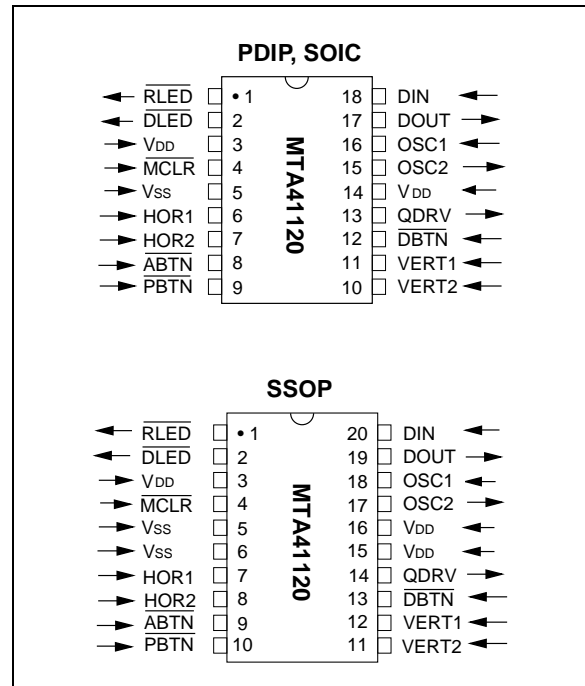
### DESCRIPTION

The MTA41120 is the heart of a simple, low-cost, mouse or trackball solution. It can be configured to operate as either an Apple Macintosh compatible mouse or trackball controller. The mouse select and drag operation can be performed with a trackball by using the optional drag lock input and drag lock LED. This allows for one handed select and drag operation when using a trackball. The MTA41120 does not require special host system device drivers.

### MTA41120

The MTA41120 is an 18-lead low-power CMOS integrated circuit. Combined with a few simple external components, a complete mouse or trackball system can be realized. An optional 2<sup>nd</sup> button is supported for systems with customized mouse drivers.

### PACKAGE TYPES



\*Apple Macintosh Compatible Host Interface  
 Apple® and Macintosh® are registered trademarks of Apple Corp.  
 Apple Desktop Bus (ADB) is a trademark of Apple Corp.  
 The microcode contained in this product is copyrighted ©1993, all rights reserved.

# MTA41120

---

---

Table of Contents	Page
1.0 Pin Descriptions .....	3
2.0 Overview .....	3
3.0 Motion Encoder Interface .....	4
4.0 Push-button Inputs .....	5
5.0 Trackball option .....	5
6.0 Electrical Characteristics .....	6
7.0 Application Example .....	11
8.0 Packaging Diagrams and Dimensions .....	16
9.0 Package Marking Information .....	19

## List of Figures

Figure 3-1: Postive Motion Sequence .....	4
Figure 3-2: Negative Motion Sequence .....	4
Figure 5-1: Trackball DragqLock Operation .....	5
Figure 6-1: Input Threshold Voltage ( $V_{TH}$ ) of all Input and I/O Pins Except $\overline{MCLR}$ and OSC1 .....	8
Figure 6-2: $V_{IH}$ , $V_{IL}$ of $\overline{MCLR}$ vs $V_{DD}$ .....	8
Figure 6-3: Input Threshold Voltage ( $V_{TH}$ ) of OSC1 Input .....	9
Figure 6-4: $I_{OH}$ vs $V_{OH}$ , $V_{DD} = 3V$ .....	9
Figure 6-5: $I_{OH}$ vs $V_{OH}$ , $V_{DD} = 5V$ .....	9
Figure 6-6: $I_{OL}$ vs $V_{OL}$ , $V_{DD} = 3V$ .....	10
Figure 6-7: $I_{OL}$ vs $V_{OL}$ , $V_{DD} = 5V$ .....	10
Figure 6-8: Timing Diagrams .....	11
Figure 7-1: MTA41120 Based Mouse or Trackball .....	12
Figure 7-2: Basic Mouse/Trackball Optical Motion Encoder .....	13
Figure 7-3: Improved Mouse/Trackball Optional Motion Encoder .....	14
Figure 7-4: Mouse/Trackball Mechanical Motion Encoder .....	15

## 1.0 PIN DESCRIPTIONS

PIN NAME	TYPE	DESCRIPTION
QDRV	Output	Active high strobed encoder drive
HOR1	Input	Horizontal quadrature Input #1
HOR2	Input	Horizontal quadrature Input #2
PBTN	Input	Primary mouse button. Active low, 0 = button depressed
ABTN	Input	Alternate mouse button. Active low, 0 = button depressed
DBTN	Input	Optional trackball drag lock button. Active low, 0 = button depressed. For mouse operation connect this pin to VDD
VERT1	Input	Vertical quadrature input #1
VERT2	Input	Vertical quadrature input #2
RLED	Output	Optional high resolution LED. Indicates mouse or trackball is in high resolution mode. If high resolution LED is not required then this pin is a no connect and should be left unconnected
DLED	Output	Optional trackball drag LED. For mouse operation this pin is a no connect and should be left unconnected
OSC1	Input	4 MHz crystal or ceramic resonator connection
OSC2	Output	4 MHz crystal or ceramic resonator connection
DIN	Input	Input data port for host communication
DOUT	OC-Output	Open Collector output for data communication with host
MCLR	Input	A "low" voltage on this pin causes a reset condition for the MTA41120 controller
VDD	Pwr	+5V
VSS	Pwr	Ground

## 2.0 OVERVIEW

The MTA41120 mouse and trackball controller is compliant with all specifications that apply to the Host Interface. Its collision detection and recovery algorithms allow it to be used in systems where one or more devices may be connected to the host interface.

The drag lock button input allows the MTA41120 to be used as either a trackball controller or a mouse controller.

The MTA41120 supports two LED indicators that indicate operation in high resolution mode and when a drag lock operation is occurring. High Resolution mode is entered in response to a command from a host and is indicated by the RLED pin being driven low.

## 3.0 MOTION ENCODER INTERFACE

The MTA41120 is designed to interface to both optical encoders that utilized LED and photo transistor pairs with a chopper wheel or mechanical encoders utilizing a commutator with wiper contacts.

The HOR and VERT inputs are sampled at ~6000 samples per second with a 4 MHz input clock. The sample rate may decrease slightly when communication traffic to or from the host is occurring. The sample rate is directly proportional to the clock frequency on the OSC1 and OSC2 pins.

Power consumption is reduced by strobing the motion encoder power each time the encoders are sampled. The MTA41120 will drive the QDRV output high 10  $\mu$ S (with 4 MHz input clock) prior to sampling the HOR and VERT inputs to give the encoders time to stabilize. The QDRV output will be driven back low 2  $\mu$ s after the sample is taken. If power consumption is not a concern then the QDRV output can be left unconnected and encoders can be powered directly from a constant supply (e.g., +5V power).

An anti-jitter algorithm is employed to eliminate false motion counting when the mouse or trackball is not moving. This is especially useful in designs employing optical encoders since the output of an optical detector is an analog signal. The anti-jitter algorithm eliminates false counting when a voltage that is not a well defined logic low or logic high is applied to either the HOR or VERT inputs.

The HOR and VERT inputs detect positive and negative delta motion. Motion direction is defined in the following state table and is illustrated in Figure 3-1 and Figure 3-2.

### Positive Motion:

Hor1, Hor2 / Vert1, Vert2	Description
0,0	
0,1	
1,1	Positive Direction Sequence
1,0	
0,0	
etc.	

### Negative Motion:

Hor1, Hor2 / Vert1, Vert2	Description
0,0	
1,0	
1,1	Negative Direction Sequence
0,1	
0,0	
etc.	

FIGURE 3-1: POSTIVE MOTION SEQUENCE

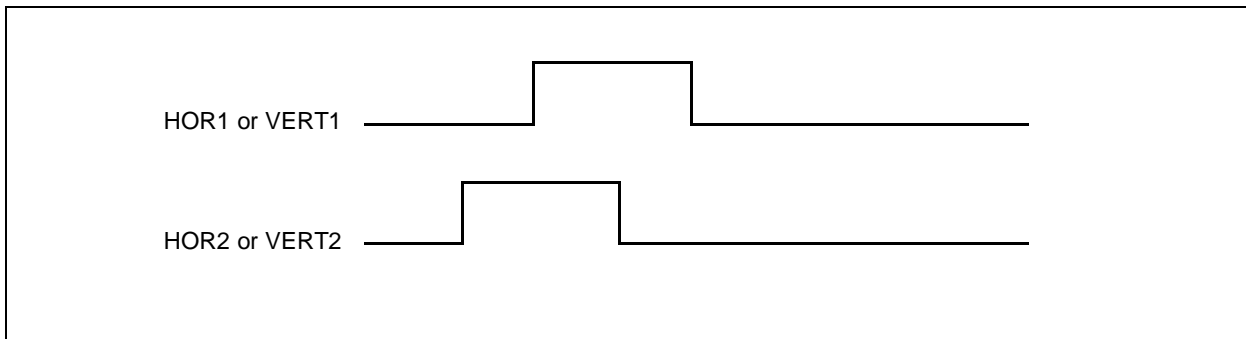
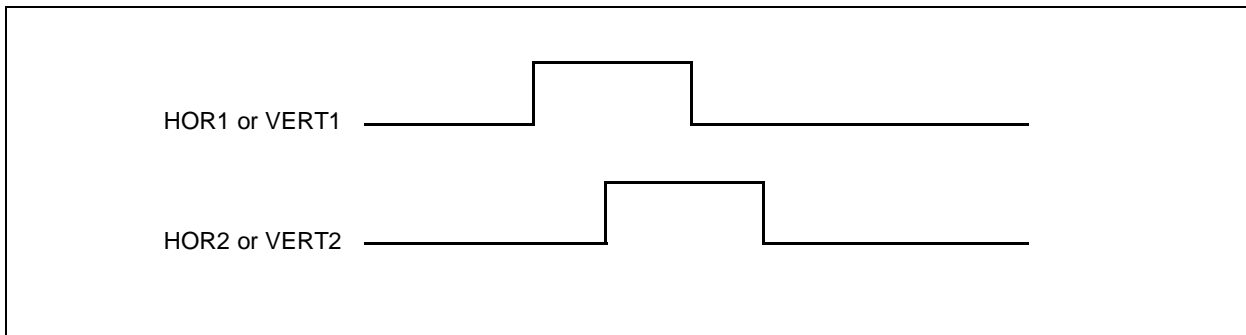


FIGURE 3-2: NEGATIVE MOTION SEQUENCE



## 4.0 PUSH-BUTTON INPUTS

The MTA41120 push-button inputs are defined to be active when the input pin is in the low state. The appropriate message data bit will be set equal to one when a low is sampled at a switch input. When a switch input is sampled in the high state the appropriate message data bit will be set equal to zero. The push-button inputs are internally debounced to eliminate “false” button status reporting.

## 5.0 TRACKBALL OPTION

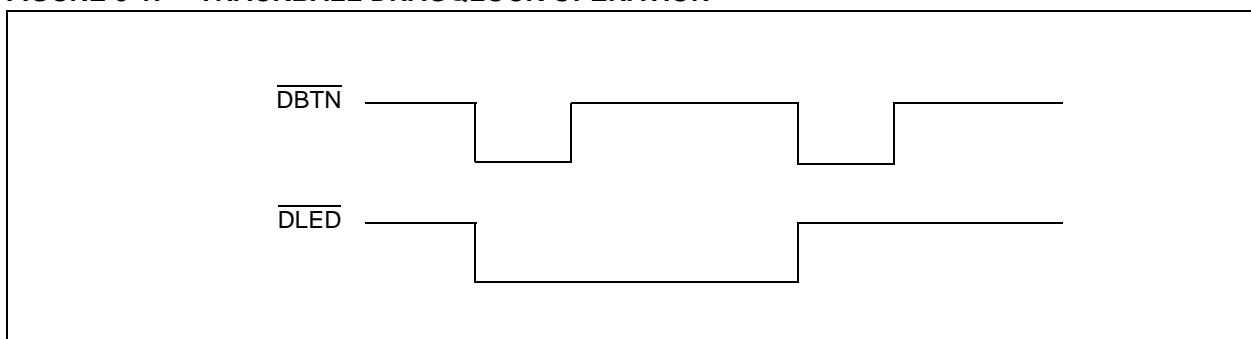
The MTA41120 can also function as a trackball controller. A trackball drag lock switch can be connected to the  $\overline{\text{DBTN}}$  input and an LED indicator connected to the  $\overline{\text{DLED}}$  output to aid in one-handed trackball operation.

When using a mouse a select and drag operation is performed by clicking on an object and holding the primary mouse button down. Moving the mouse then drags the object to the desired location. When the primary button is released the object is placed at the desired location. However, when the same select and drag operation is performed using a trackball, it may be difficult to hold the button depressed and guide the trackball with the same hand.

The MTA41120’s “drag lock” feature allows this function to be accomplished with one hand. The drag lock is set to the “locked” state by momentarily applying a low to the  $\overline{\text{DBTN}}$  input. This “locked” state is equivalent to depressing and holding the primary mouse button. The user then guides the object to the desired location without having to hold a button depressed and simultaneously guide the trackball. The object is placed and the “lock” is released when a low (e.g., button depressed) is momentarily applied to any button input.

The  $\overline{\text{DLED}}$  output is latched in the low state (0V) when the  $\overline{\text{DBTN}}$  input is sampled low (Figure 5-1). The  $\overline{\text{DLED}}$  output will remain low (“locked”) until the  $\overline{\text{DBTN}}$  input is sampled high and then sampled low again. Exiting the locked state also occurs if the  $\overline{\text{PBTN}}$  input or  $\overline{\text{SBTN}}$  input is sampled low when the  $\overline{\text{DLED}}$  output is low. When the  $\overline{\text{DLED}}$  output is in low “locked” state, the Primary Button depressed bit in the status message is set high.

**FIGURE 5-1: TRACKBALL DRAGLOCK OPERATION**



## 6.0 ELECTRICAL CHARACTERISTICS

### 6.1 Absolute Maximum Ratings †

Ambient temperature under bias	-55°C to +125°C
Storage temperature	-65°C to +150°C
Voltage on any pin with respect to VSS (except VDD and $\overline{\text{MCLR}}$ )	-0.6V to (V <sub>DD</sub> +0.6V)
Voltage on $\overline{\text{MCLR}}$ pin with respect to VSS	0V to +14.0V
Voltage on VDD with respect to VSS	0V to +9.5V
Total power dissipation (Note 2)	800 mW
Maximum current out of VSS pin	150 mA
Maximum current into VDD pin	50 mA
Maximum current into input pin	±500 mA
Maximum output current sunked by any I/O or output pin	25 mA
Maximum output current sourced by any I/O or output pin	20 mA

#### Notes:

1. Voltage spikes below VSS at the  $\overline{\text{MCLR}}$  pin, inducing currents greater than 80 mA may cause latch-up. Thus, a series resistor of 50 to 100Ω should be used when applying a "low" level to this pin, rather than connecting this pin directly to VSS.
2. Total power dissipation should not exceed 800 mW for the package. The total power dissipation is calculated as follows:  $P_{DIS} = V_{DD} \times (I_{DD} - \sum I_{OH}) + \sum \{(V_{DD} - V_{OH}) \times I_{OH}\} + \sum (V_{OL} \times I_{OL})$
- 3.

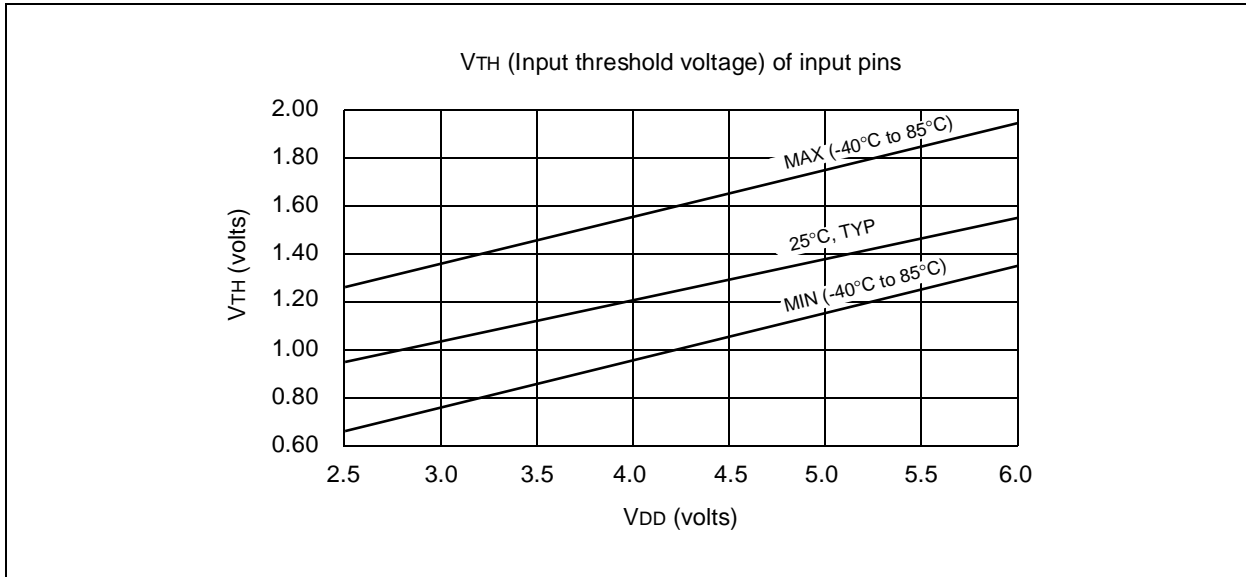
† **Notice:** Stresses above those listed under "Absolute Maximum Ratings" may cause permanent damage to the device. This is a stress rating only and functional operation of the device at those or any other conditions above those indicated in the operation listings of this specification is not implied. Exposure to maximum rating conditions for extended periods may affect device reliability.

## 6.2 DC Characteristics MTA41120 (Commercial)

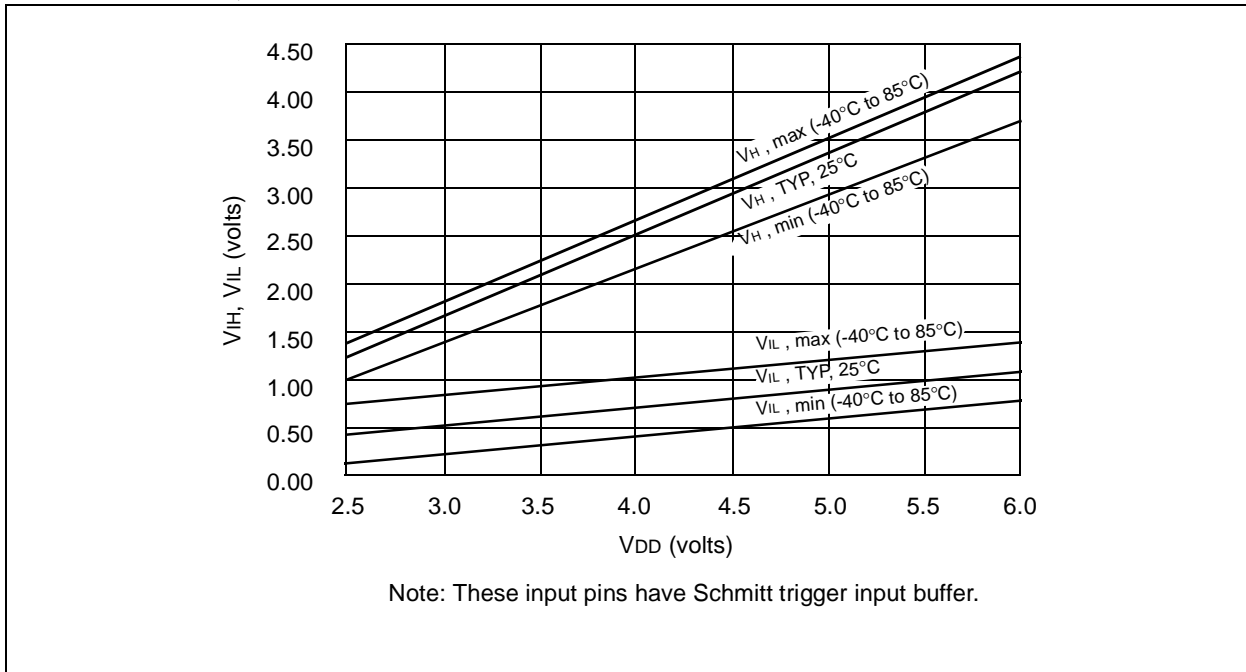
<b>DC CHARACTERISTICS</b>		Standard Operating Conditions (unless otherwise stated). Operating Temperature 0°C < TA < 70°C for commercial. Operating Voltage V <sub>DD</sub> = 3.0V to 5.5V unless otherwise stated.				
<b>Characteristic</b>	<b>Sym.</b>	<b>Min.</b>	<b>Typ.</b>	<b>Max.</b>	<b>Units</b>	<b>Conditions</b>
Supply Voltage	V <sub>DD</sub>	3.0		6.25	V	FOSC = DC to 4 MHz
V <sub>DD</sub> start voltage to guarantee power-on reset	V <sub>POR</sub>		V <sub>SS</sub>		V	
V <sub>DD</sub> rise rate to guarantee power-on reset	SV <sub>DD</sub>	0.05*			V/MS	
Supply Current	I <sub>DD</sub>			3.3	mA	FOSC = 4 MHz , V <sub>DD</sub> = 5.5V
Input Low Voltage MCLR (Schmitt trigger) OSC1 (Schmitt trigger) All other Inputs	V <sub>ILMC</sub> V <sub>ILOSC</sub> V <sub>IL</sub>			.15 V <sub>DD</sub> .3 V <sub>DD</sub> .2 V <sub>DD</sub>	V V V	
Input High Voltage MCLR (Schmitt trigger) OSC1 (Schmitt trigger) All other Inputs	V <sub>IHMC</sub> V <sub>IHOSC</sub> V <sub>IH</sub>	.85 V <sub>DD</sub> .7 V <sub>DD</sub> 2.0 .45 V <sub>DD</sub> .36 V <sub>DD</sub>		V <sub>DD</sub> V <sub>DD</sub> V <sub>DD</sub> V <sub>DD</sub> V <sub>DD</sub>	V V V	4.45V ≤ V <sub>SS</sub> ≤ 5.5V V <sub>DD</sub> < 4.45V V <sub>DD</sub> > 5.5V
Input Leakage Current MCLR MCLR OSC1 (Schmitt trigger) All other Inputs	I <sub>ILMCL</sub> I <sub>ILMCH</sub> I <sub>ILMCH</sub> I <sub>IL</sub>	-5  -3 -1	 0.5 0.5 0.5	 +5 +3 +1	μA μA μA μA	V <sub>PN</sub> = V <sub>SS</sub> + 0.25V V <sub>PN</sub> = V <sub>DD</sub> V <sub>SS</sub> ≤ V <sub>PN</sub> ≤ V <sub>DD</sub> V <sub>SS</sub> ≤ V <sub>PN</sub> ≤ V <sub>DD</sub>
Output Low Voltage OSC2 All other Outputs	V <sub>OL</sub> V <sub>OL</sub>			0.6V 0.6V	V V	I <sub>OL</sub> = 1.6 mA, V <sub>DD</sub> = 4.5V I <sub>OL</sub> = 8.7 mA, V <sub>DD</sub> = 4.5V
Output High Voltage OSC2 All other Outputs	V <sub>OH</sub> V <sub>OH</sub>	V <sub>DD</sub> - .7 V <sub>DD</sub> - .7			V V	I <sub>OH</sub> = -1.0 mA, V <sub>DD</sub> = 4.5V I <sub>OH</sub> = -5.4 mA, V <sub>DD</sub> = 4.5V

\*These parameters are based on characterization and are not tested.

**FIGURE 6-1: INPUT THRESHOLD VOLTAGE ( $V_{TH}$ ) OF ALL INPUT AND I/O PINS EXCEPT  $\overline{MCLR}$  AND OSC1**

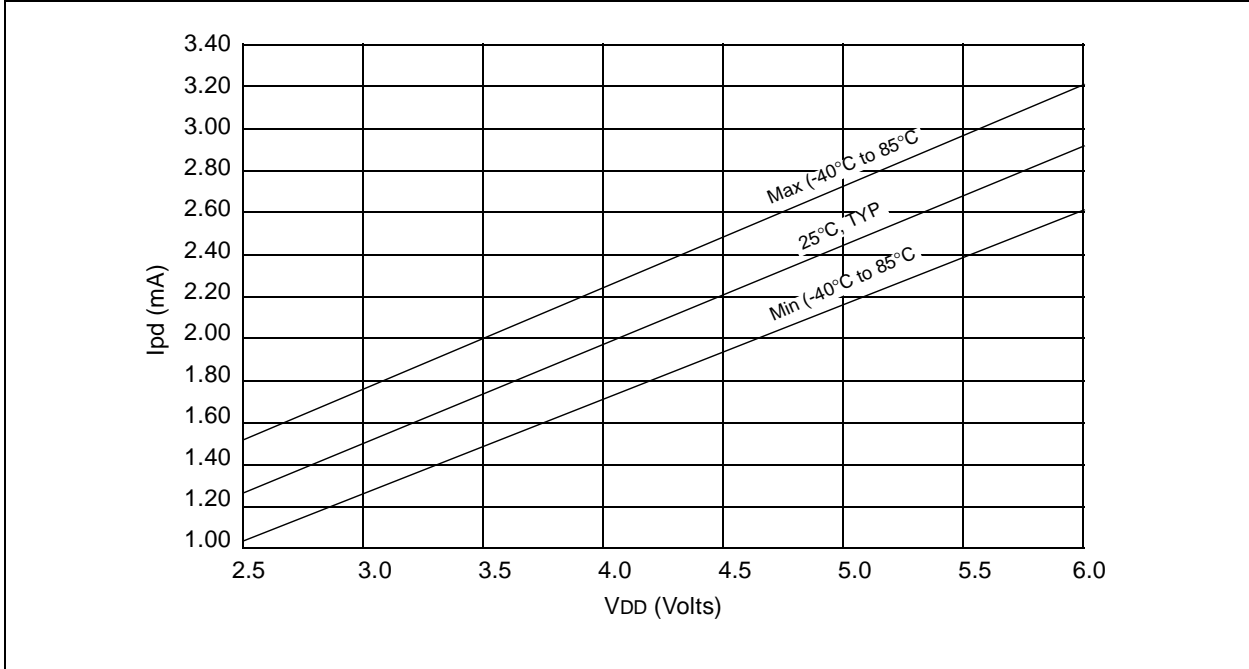


**FIGURE 6-2:  $V_{IH}$ ,  $V_{IL}$  OF  $\overline{MCLR}$  vs  $V_{DD}$**

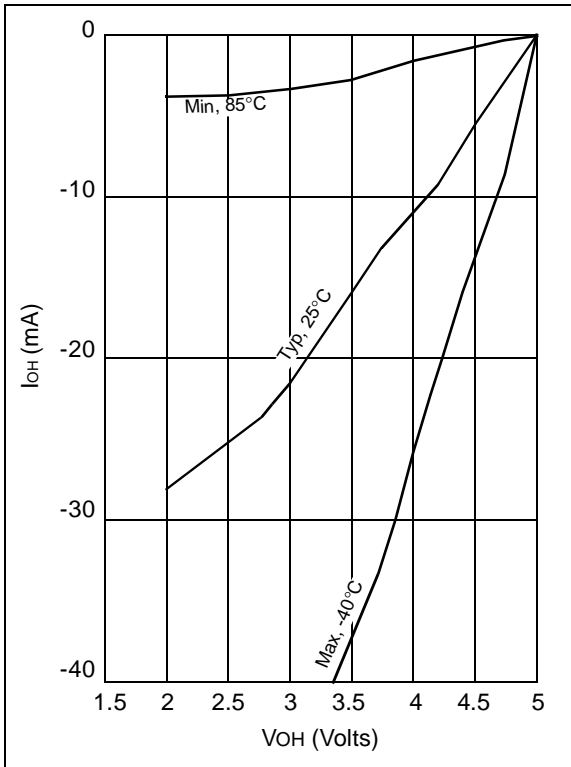




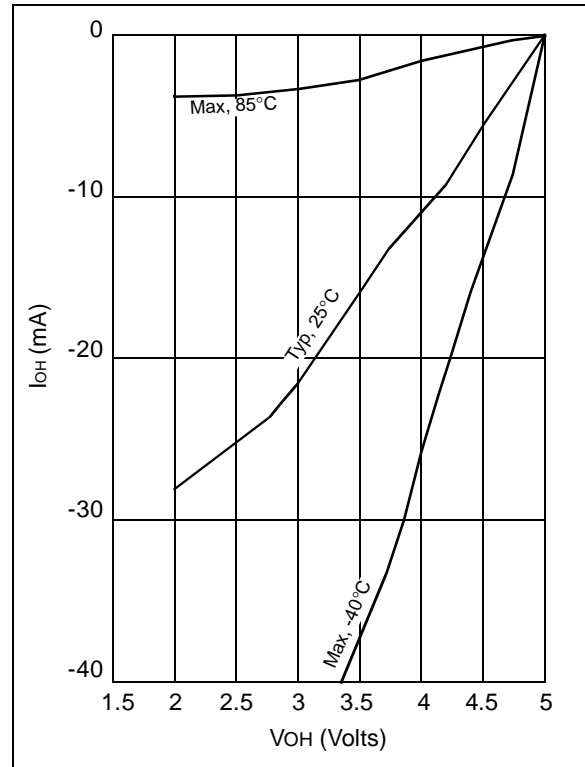
**FIGURE 6-3: INPUT THRESHOLD VOLTAGE ( $V_{TH}$ ) OF OSC1 INPUT**



**FIGURE 6-4:  $I_{OH}$  vs  $V_{OH}$ ,  $V_{DD} = 3V$**

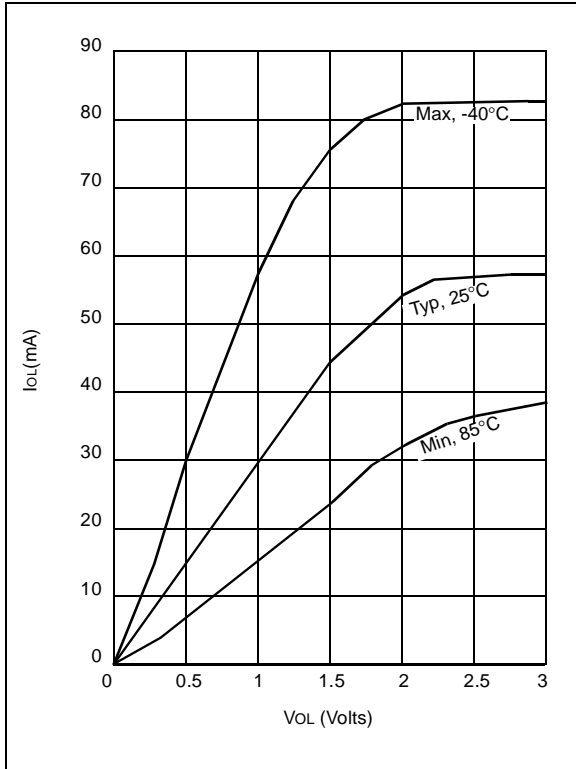


**FIGURE 6-5:  $I_{OH}$  vs  $V_{OH}$ ,  $V_{DD} = 5V$**

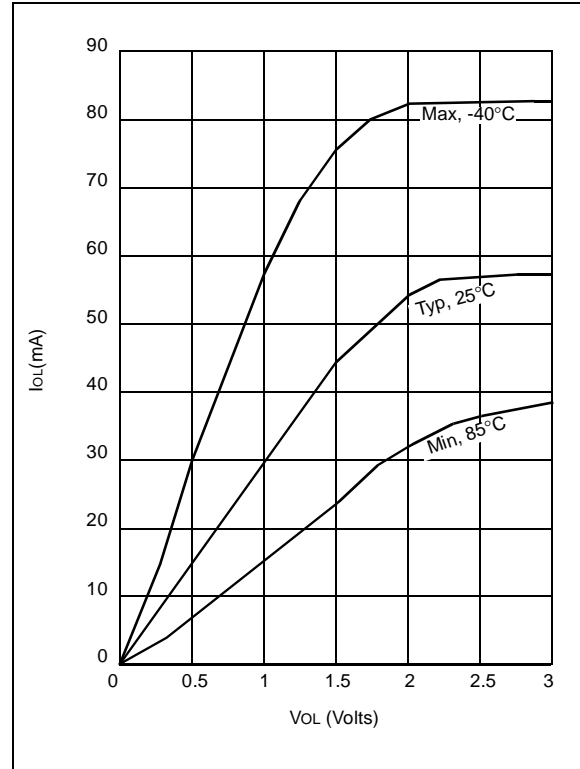


# MTA41120

**FIGURE 6-6: I<sub>OL</sub> vs V<sub>OL</sub>, V<sub>DD</sub> = 3V**



**FIGURE 6-7: I<sub>OL</sub> vs V<sub>OL</sub>, V<sub>DD</sub> = 5V**



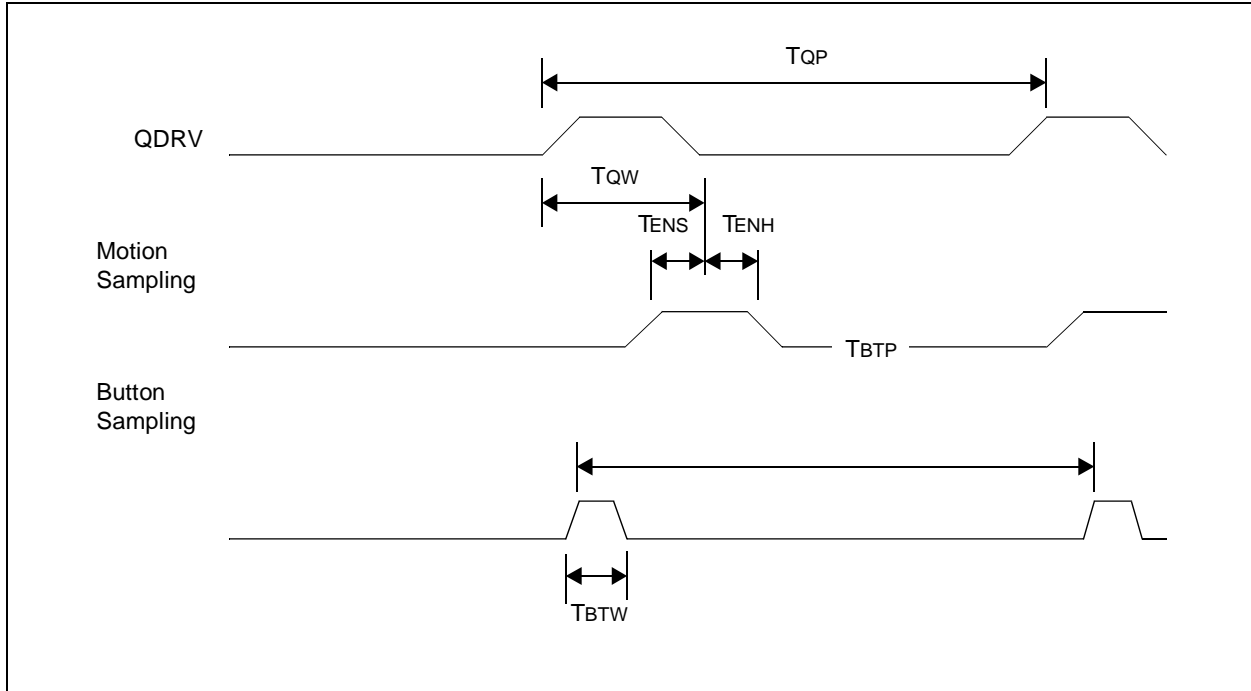
## 6.3 AC Characteristics MTA41120 (Commercial)

<b>AC CHARACTERISTICS</b>		Standard Operating Conditions (unless otherwise stated). Operating Temperature 0°C < TA < 70°C for commercial. Operating Voltage V <sub>DD</sub> = 3.0V to 5.5V unless otherwise stated. Oscillator Frequency = 4 MHz.				
Characteristic	Sym.	Min.	Typ.	Max.	Units	Conditions
Oscillator Frequency	FOSC	DC		4	MHz	
Motion Encoder Timing						
QDRV						
Pulse Period	T <sub>QP</sub> (NOTE 2)		166		μs	
Pulse Width	T <sub>QW</sub>	11	12	13	μs	
HOR1, HOR2, VERT1, VERT2						
Input Sample Setup Time	T <sub>ENS</sub>	2			μs	Before QDRV falling edge.
Input Sample Hold	T <sub>ENH</sub>			0	ns	After QDRV falling edge.
Button Input Timing						
PBTN, SBTN, DBTN						
Input Sample Period	T <sub>BP</sub> (NOTE 2)			10	ms	
Input Sample Window width	T <sub>BTU</sub>			280	ns	
RESET Timing						
MCLR Pulse Width (low)	T <sub>MCL</sub>	100			ns	
Oscillator Start-up Timer Period	T <sub>OST</sub> (NOTE 1)	9	18	30	ms	V <sub>DD</sub> = 5.0V

**Notes:**

1. These parameters are based on characterization and are not tested.
2. Sampling period can increase if device is receiving data from host or when transmitting to host.

**FIGURE 6-8: TIMING DIAGRAMS**



## 7.0 APPLICATION EXAMPLE

The MTA41120 controller can be configured as either a mouse or trackball controller. Trackball systems require the addition of the components labeled as trackball only. These components allow support of a drag lock switch and indicator. A pull-up resistor for the drag lock switch must be included in trackball systems. For a mouse the DBTN input is simply connected to VDD.

Three examples of motion encoders are shown in the schematics (Document number 41XXXEN). Two types of optical encoders and a mechanical type are shown. Since the MTA41120 employs an anti-jitter algorithm, the "basic" style of optical encoder or the mechanical encoder are both recommended for use with the MTA41120. Use of the "improved" style of optical encoder that employs comparators, may only be necessary in high noise environments.

All button switches should be of the momentary contact type, including the drag lock switch.

FIGURE 7-1: MTA41120 BASED MOUSE OR TRACKBALL

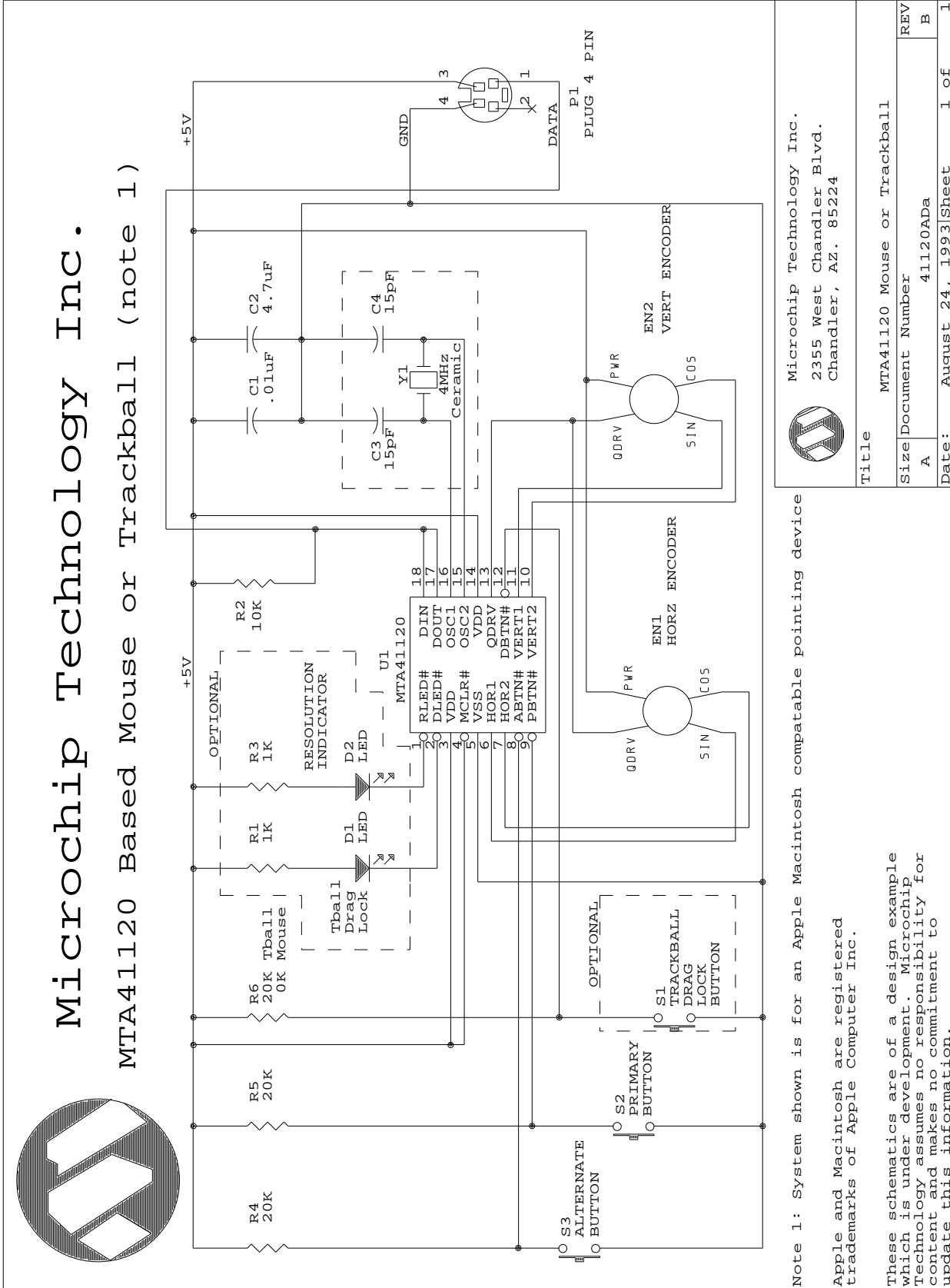


FIGURE 7-2: BASIC MOUSE/TRACKBALL OPTICAL MOTION ENCODER

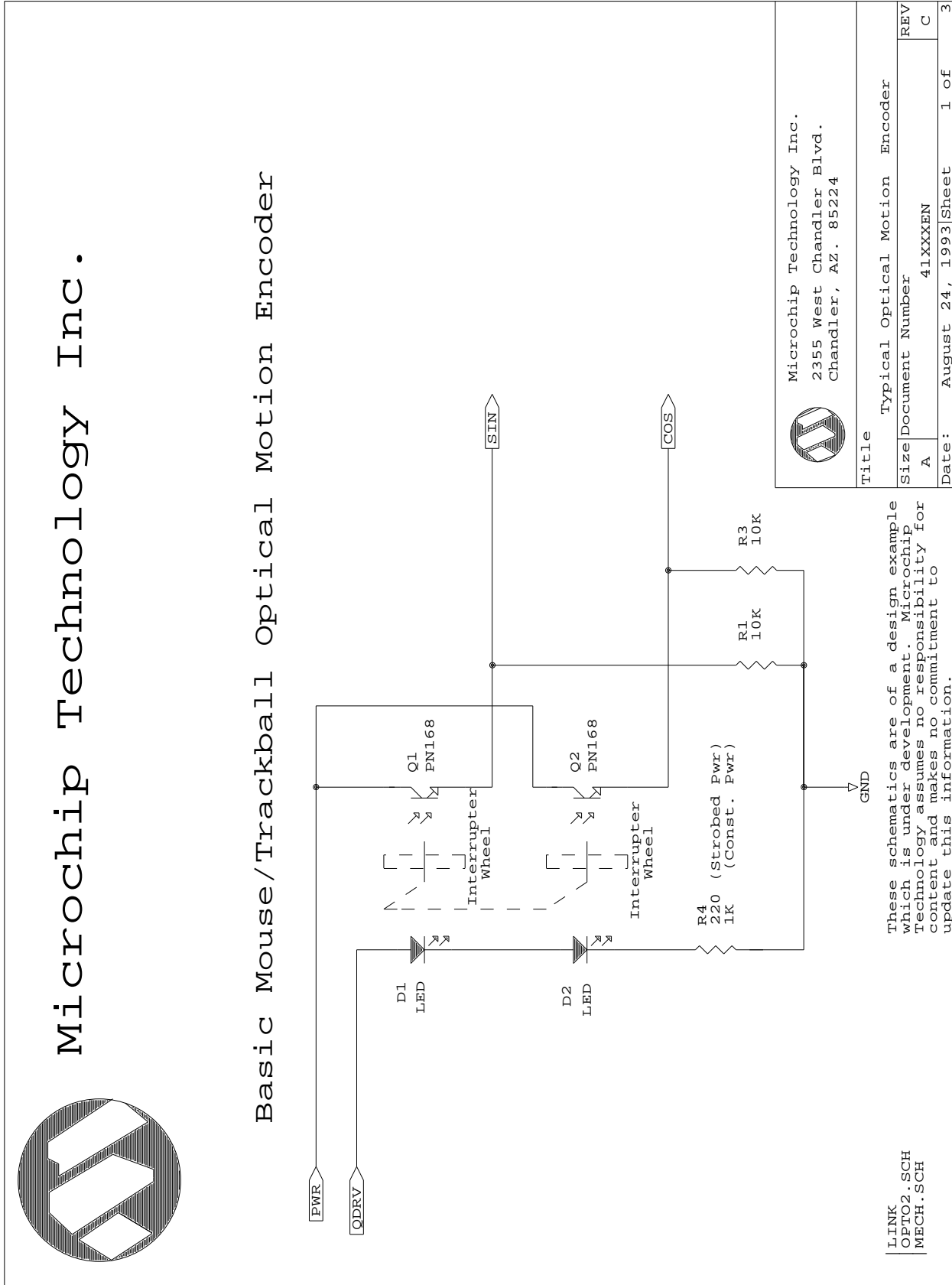


FIGURE 7-3: IMPROVED MOUSE/TRACKBALL OPTIONAL MOTION ENCODER

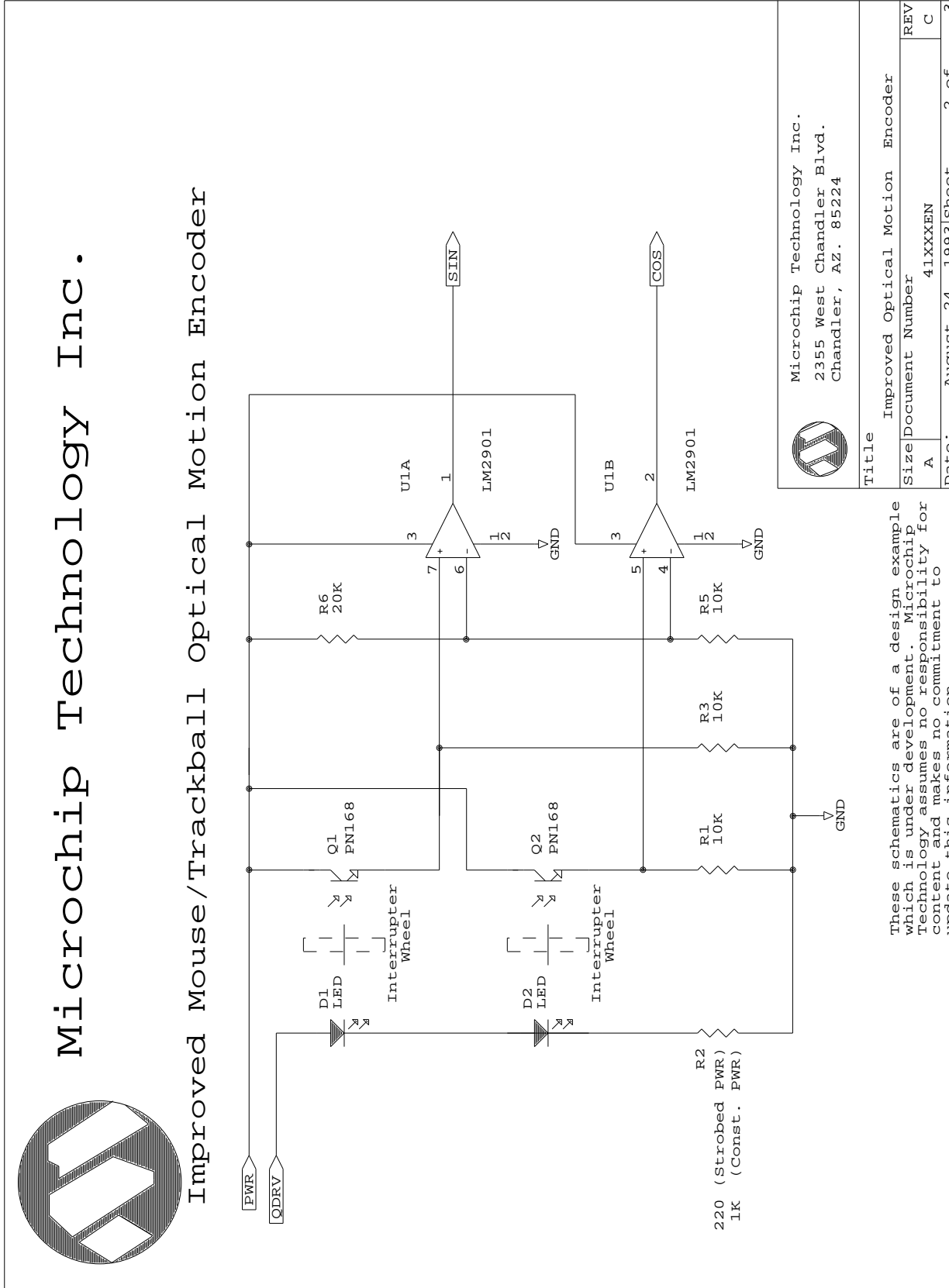
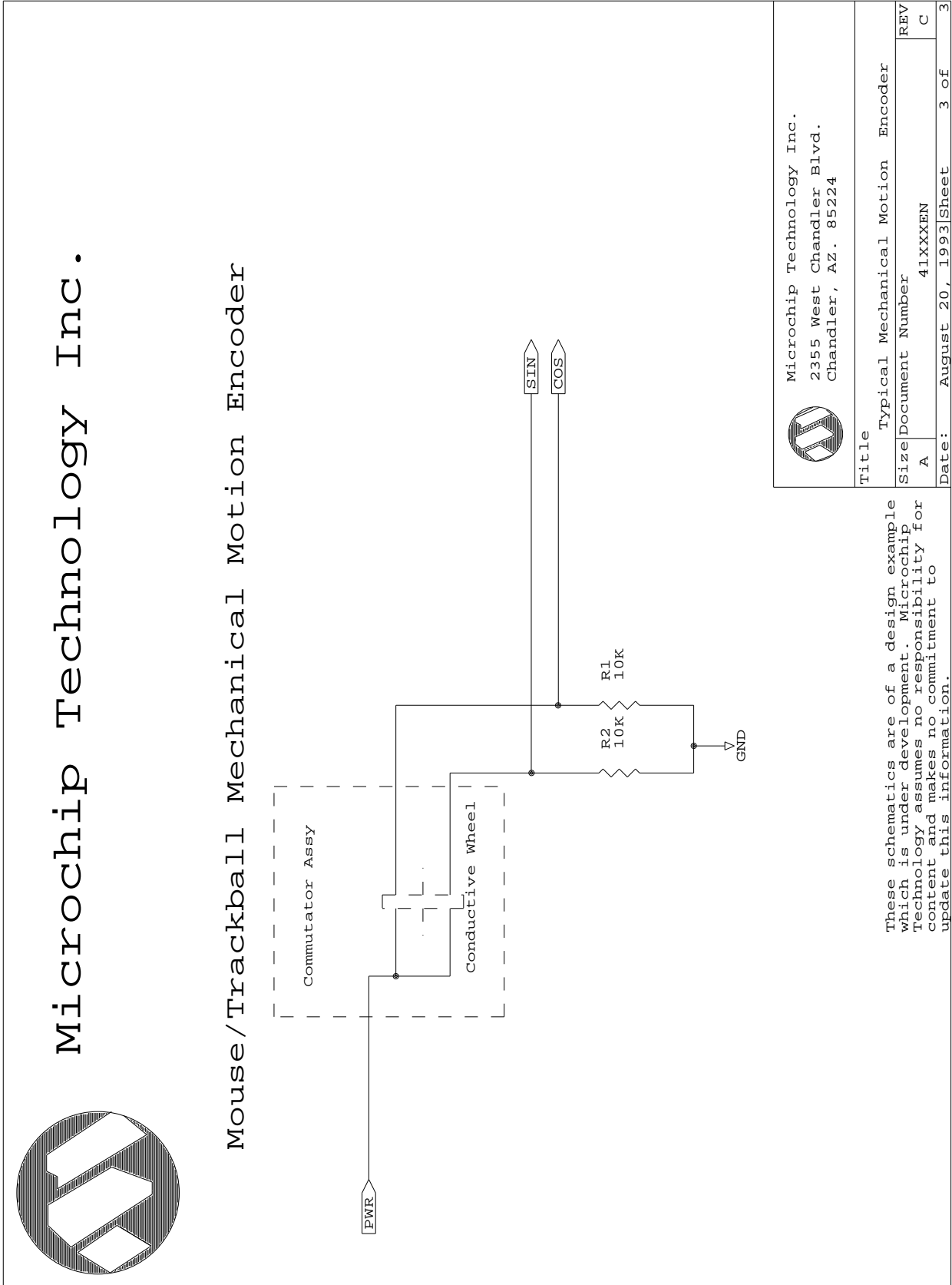


FIGURE 7-4: MOUSE/TRACKBALL MECHANICAL MOTION ENCODER



Microchip Technology Inc.

Mouse/Trackball Mechanical Motion Encoder



Microchip Technology Inc.  
2355 West Chandler Blvd.  
Chandler, AZ. 85224

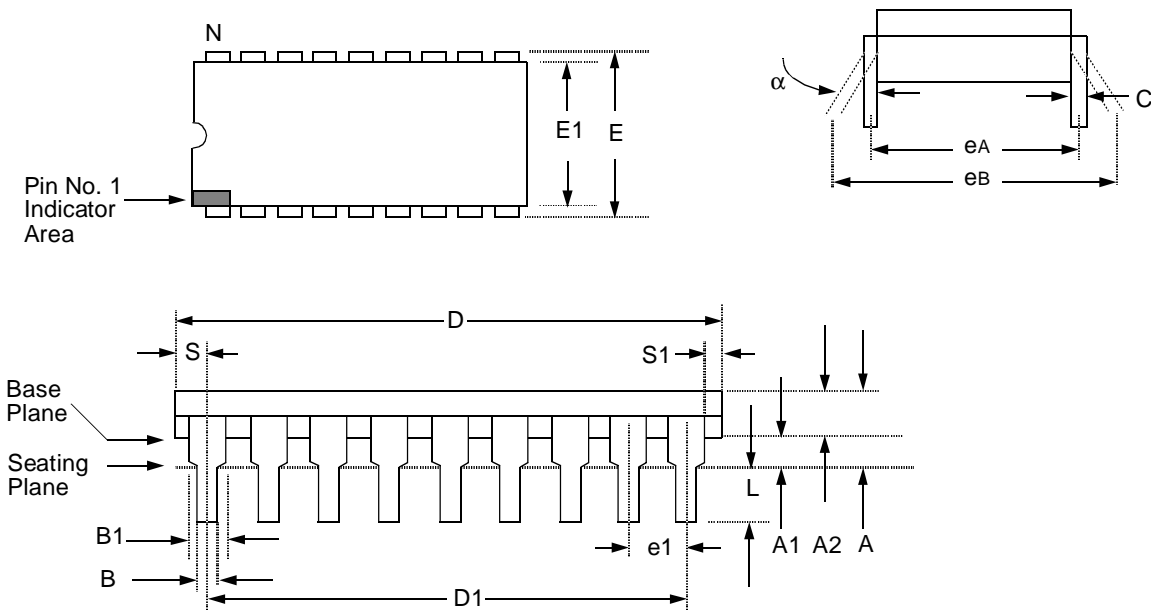
Title		Typical Mechanical Motion Encoder	
Size	Document Number	REV	
A	41XXXXEN	C	
Date:	August 20, 1993	Sheet	3 of 3

These schematics are of a design example which is under development. Microchip Technology assumes no responsibility for content and makes no commitment to update this information.

# MTA41120

## 8.0 PACKAGING DIAGRAMS AND DIMENSIONS

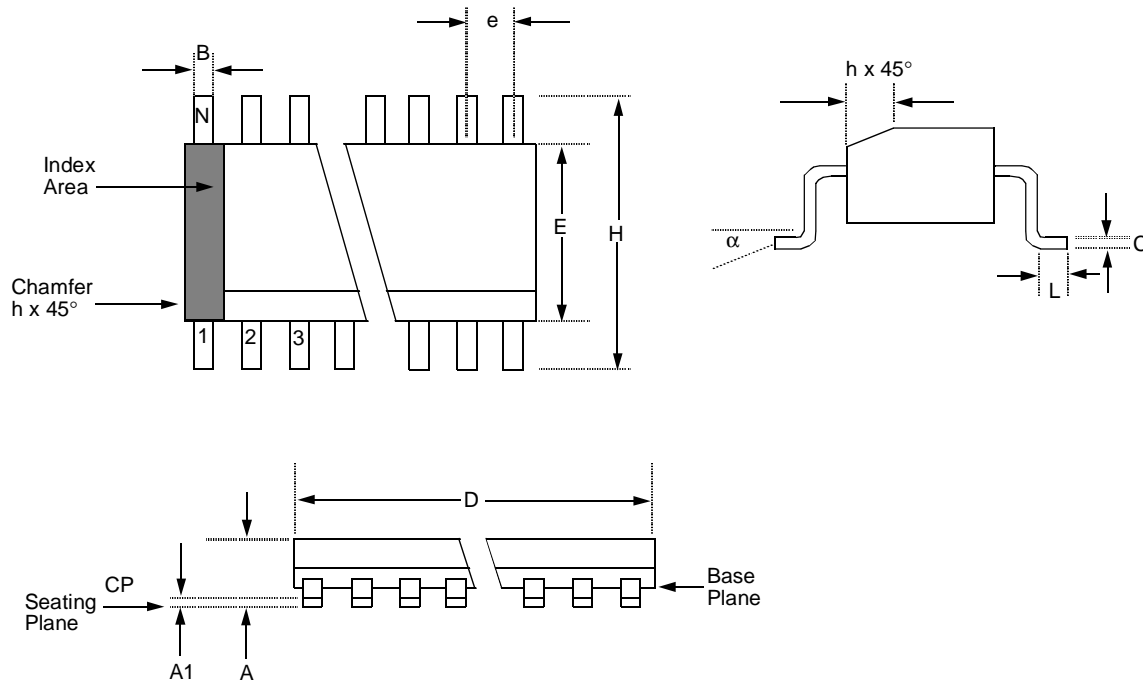
### 8.1 18-Lead Plastic Dual In-Line (300mil)



Package Group: Plastic Dual In-Line (PLA)						
Symbol	Millimeters			Inches		
	Min	Max	Notes	Min	Max	Notes
$\alpha$	0°	10°		0°	10°	
A	-	4.064		-	0.160	
A <sub>1</sub>	0.381	-		0.015	-	
A <sub>2</sub>	3.048	3.810		0.120	0.150	
B	0.3556	0.5588		0.014	0.022	
B <sub>1</sub>	1.524	1.524	Reference	0.060	0.060	Reference
C	0.203	0.381	Typical	0.008	0.015	Typical
D	22.479	23.495		0.885	0.925	
D <sub>1</sub>	20.320	20.320	Reference	0.800	0.800	Reference
E	7.620	8.255		0.300	0.325	
E <sub>1</sub>	6.096	7.112		0.240	0.280	
e <sub>1</sub>	2.4892	2.5908	Typical	0.098	0.102	Typical
eA	7.620	7.620	Reference	0.300	0.300	Reference
eB	7.874	9.906		0.310	0.390	
L	3.048	3.556		1.120	0.140	
N	18	18		18	18	
S	0.889	-		0.035	-	
S <sub>1</sub>	0.127	-		0.005	-	

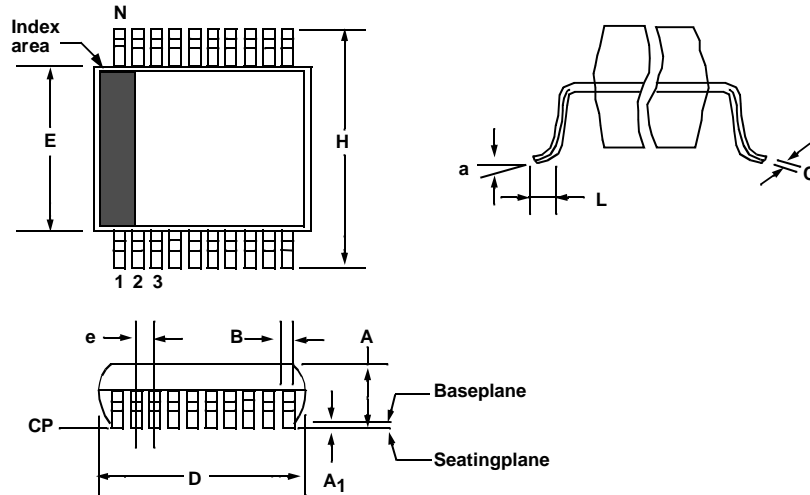


## 8.2 18-Lead Plastic Surface Mount (SOIC - Wide, 300 mil Body)



Package Group: Plastic SOIC (SO)						
Symbol	Millimeters			Inches		
	Min	Max	Notes	Min	Max	Notes
$\alpha$	0°	8°		0°	8°	
A	2.3622	2.6416		0.093	0.104	
A <sub>1</sub>	0.1016	0.29972		0.004	0.0118	
B	0.3556	0.4826		0.014	0.019	
C	0.2413	0.3175		0.0095	0.0125	
D	11.3538	11.7348		0.447	0.462	
E	7.4168	7.5946		0.292	0.299	
e	1.270	1.270	Reference	0.050	0.050	Reference
H	10.0076	10.6426		0.394	0.419	
h	0.381	0.762		0.015	0.030	
L	0.4064	1.143		0.016	0.045	
N	18	18		18	18	
CP	-	0.1016		-	0.004	

## 8.3 20-Lead Plastic Surface Mount (SSOP - 209 mil Body 5.30mm)



Package Group: Plastic SSOP

Symbol	Millimeters		Notes	Inches		Notes
	Min	Max		Min	Max	
$\alpha$	0°	8°		0°	8°	
A	1.73	1.99		0.068	0.078	
A <sub>1</sub>	0.05	0.21		0.002	0.008	
B	0.25	0.38		0.010	0.015	
C	0.13	0.22		0.005	0.009	
D	7.07	7.33		0.278	0.289	
E	5.2	5.38		0.205	0.212	
e	0.65	0.65	Reference	0.0256	0.0256	Reference
H	7.65	7.90		0.301	0.311	
L	0.55	0.95		0.022	0.037	
N	20	20		20	20	
CP	-	0.1016		-	0.004	

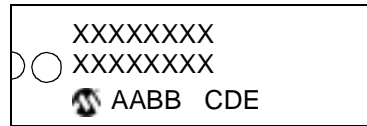
Symbol List for Shrink Small Outline Package Parameter

Symbol	Description of Parameters
$\alpha$	Angular spacing between min. and max. lead positions measured at the gauge plane
A	Distance between seating plane to highest point of body
A <sub>1</sub>	Distance between seating plane and base plane
B	Width of terminals
C	Thickness of terminals
D	Largest overall package parameter of length
E	Largest overall package width parameter not including leads
e	Linear spacing of true minimum lead position center line to center line
H	Largest overall package dimension of width
L	Length of terminal for soldering to a substrate
N	Total number of potentially usable lead positions
CP	Seating plane coplanarity

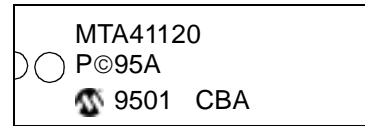
- Notes:**
1. Controlling parameter: mm.
  2. All packages are gull wing lead form.
  3. "D" and "E" are reference datums and do not include mold flash or protrusions. Mold flash or protrusions shall not exceed 0.15mm .006 package ends and .010" on sides.
  4. A .25 mm visual index feature must be located within the crosshatched area to indicate pin 1 position.
  5. Terminal numbers are shown for reference.

## 9.0 PACKAGE MARKING INFORMATION

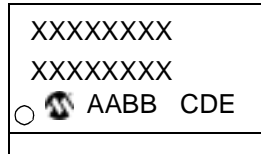
### 18-Lead PDIP



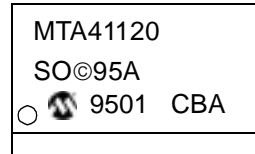
### Example



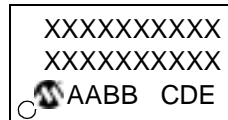
### 18-Lead SOIC (.300")



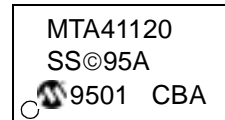
### Example



### 20-Lead SSOP



### Example

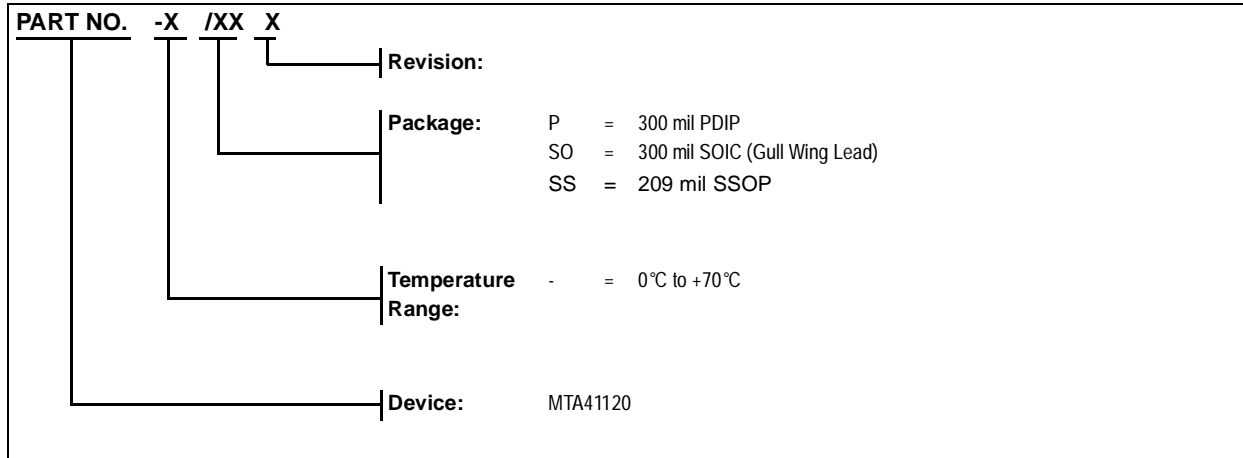


<b>Legend:</b> MM...M	Microchip part number information
AA	Year code (last 2 digits of calendar year)
BB	Week code (week of January 1 is week '01')
C	Facility code of the plant at which wafer is manufactured. C = Chandler, Arizona, U.S.A.
D	Mask revision number
E	Assembly code of the plant or country of origin in which
<b>Note:</b> In the event the full Microchip part number can not be marked on one line, it will be carried over to the next line.	

# MTA41120

## MTA41120 Product Identification System

To order or to obtain information (e.g., on pricing or delivery), please use the listed part numbers, and refer to the factory or the listed sales offices.



### AMERICAS

#### Corporate Office

Microchip Technology Inc.  
2355 West Chandler Blvd.  
Chandler, AZ 85224-6199  
Tel: 602 786-7200 Fax: 602 786-7277

#### Atlanta

Microchip Technology Inc.  
500 Sugar Mill Road, Suite 200B  
Atlanta, GA 30350  
Tel: 404 640-0034 Fax: 404 640-0307

#### Boston

Microchip Technology Inc.  
Five The Mountain Road, Suite 120  
Framingham, MA 01701  
Tel: 508 820-3334 Fax: 508 820-4326  
After July 31, 1995:  
Tel: 508 480-9990 Fax: 508 420-8575

#### Chicago

Microchip Technology Inc.  
333 Pierce Road, Suite 180  
Itasca, IL 60143  
Tel: 708 285-0071 Fax: 708 285-0075

#### Dallas

Microchip Technology Inc.  
14651 Dallas Parkway, Suite 816  
Dallas, TX 75240-8809  
Tel: 214 991-7177 Fax: 214 991-8588

#### Dayton

Microchip Technology Inc.  
35 Rockridge Road  
Englewood, OH 45322  
Tel: 513 832-2543 Fax: 513 832-2841

#### Los Angeles

Microchip Technology Inc.  
18201 Von Karman, Suite 455  
Irvine, CA 92715  
Tel: 714 263-1888 Fax: 714 263-1338

#### New York

Microchip Technology Inc.  
150 Motor Parkway, Suite 416  
Hauppauge, NY 11788  
Tel: 516 273-5305 Fax: 516 273-5335

### AMERICAS (continued)

#### San Jose

Microchip Technology Inc.  
2107 North First Street, Suite 590  
San Jose, CA 95131  
Tel: 408 436-7950 Fax: 408 436-7955

### ASIA/PACIFIC

#### Hong Kong

Microchip Technology Inc.  
Unit No. 3002-3004, Tower 1  
Metroplaza  
223 Hing Fong Road  
Kwai Fong, N.T. Hong Kong  
Tel: 852 2 401 1200 Fax: 852 2 401 3431

#### Korea

Microchip Technology Korea  
168-1, Youngbo Bldg. 3 Floor  
Samsung-Dong, Kangnam-Ku,  
Seoul, Korea  
Tel: 82 2 554 7200 Fax: 82 2 558 5934

#### Singapore

Microchip Technology Inc.  
200 Middle Road  
#10-03 Prime Centre  
Singapore 0718  
Tel: 65 334 8870 Fax: 65 334 8850

#### Taiwan

Microchip Technology Taiwan  
10F-1C 207  
Tung Hua North Road  
Taipei, Taiwan, ROC  
Tel: 886 2 717 7175 Fax: 886 2 545 0139

### EUROPE

#### United Kingdom

Arizona Microchip Technology Ltd.  
Unit 6, The Courtyard  
Meadow Bank, Furlong Road  
Bourne End, Buckinghamshire  
SL8 5AJ  
Tel: 44 0 1628 851077 Fax: 44 0 1628 850259

#### France

Arizona Microchip Technology SARL  
2 Rue du Buisson aux Fraises  
91300 Massy - France  
Tel: 33 1 69 53 63 20 Fax: 33 1 69 30 90 79

#### Germany

Arizona Microchip Technology GmbH  
Gustav-Heinemann-Ring 125  
D-81739 Muenchen, Germany  
Tel: 49 89 627 144 0 Fax: 49 89 627 144 44

#### Italy

Arizona Microchip Technology SRL  
Centro Direzionale Colleoni  
Palazzo Pegaso Ingresso No. 2  
Via Paracelso 23, 20041  
Agrate Brianza (MI) Italy  
Tel: 39 039 689 9939 Fax: 39 039 689 9883

### JAPAN

Microchip Technology Intl. Inc.  
Benex S-1 6F  
3-18-20, Shin Yokohama  
Kohoku-Ku, Yokohama  
Kanagawa 222 Japan  
Tel: 81 45 471 6166 Fax: 81 45 471 6122



**MICROCHIP**

Printed in the USA, 6/6/95  
© 1995, Microchip Technology Inc.

Information contained in this publication regarding device applications and the like is intended by way of suggestion only. No representation or warranty is given and no liability is assumed by Microchip Technology Inc. with respect to the accuracy or use of such information. Use of Microchip's products as critical components in life support systems is not authorized except with express written approval by Microchip. The Microchip logo and name are registered trademarks of Microchip Technology Inc. All rights reserved. All other trademarks mentioned herein are the property of their respective companies.