

DATA SHEET

TDA5736; TDA5737

5 V VHF, hyperband and UHF
mixer/oscillators for TV and VCR
3-band tuners

Product specification
Supersedes data of 1996 Oct 16
File under Integrated Circuits, IC02

1996 Oct 25

5 V VHF, hyperband and UHF mixer/oscillators for TV and VCR 3-band tuners

TDA5736; TDA5737

FEATURES

- Balanced mixer with a common emitter input for band A (single input)
- 2-pin oscillator for band A
- Balanced mixer with a common base input for bands B and C (balanced input)
- 3-pin oscillator for band B
- 4-pin oscillator for band C
- Local oscillator buffer output for external prescaler
- SAW filter preamplifier with a low output impedance to drive the SAW filter directly
- Band gap voltage stabilizer for oscillator stability
- Electronic band switch
- External IF filter between the mixer output and the IF amplifier input.

GENERAL DESCRIPTION

The TDA5736 and TDA5737 are monolithic integrated circuits that perform the mixer/oscillator functions for bands A, B and C in TV and VCR tuners. These low power mixer/oscillators require a power supply of 5 V and are available in a very small package.

These devices give the designer the capability to design an economical and physically small 3-band tuner.

They are suitable for European standards, as illustrated in Fig.17, with the following RF bands: 48.25 to 168.25 MHz, 175.25 to 447.25 MHz and 455.25 to 855.25 MHz.

With an appropriate tuned circuit, they are also suitable for NTSC all channel tuners (USA and Japan).

The tuner development time can be drastically reduced by using these devices.

APPLICATIONS

- 3-band all channel TV and VCR tuners
- Any standard.

QUICK REFERENCE DATA

SYMBOL	PARAMETER	CONDITIONS	MIN.	TYP.	MAX.	UNIT
V_P	supply voltage		–	5.0	–	V
I_P	supply current		–	50	–	mA
f_{RF}	frequency range	RF input; band A; note 1	41	–	171	MHz
		RF input; band B; note 1	166	–	451	MHz
		RF input; band C; note 1	446	–	861	MHz
G_V	voltage gain	band A	–	23	–	dB
		band B	–	34	–	dB
		band C	–	34	–	dB
NF	noise figure	band A	–	7.5	–	dB
		band B	–	8	–	dB
		band C	–	9	–	dB
V_o	output voltage level causing 1% cross modulation in channel	band A	–	116	–	dB μ V
		band B	–	115	–	dB μ V
		band C	–	115	–	dB μ V

Note

1. The limits are related to the tank circuits used in Fig.17 and the intermediate frequency. Frequency bands may be adjusted by the choice of external components.

5 V VHF, hyperband and UHF mixer/oscillators for TV and VCR 3-band tuners

TDA5736; TDA5737

ORDERING INFORMATION

TYPE NUMBER	PACKAGE		
	NAME	DESCRIPTION	VERSION
TDA5736M	SSOP24	plastic shrink small outline package; 24 leads; body width 5.3 mm	SOT340-1
TDA5737M	SSOP24	plastic shrink small outline package; 24 leads; body width 5.3 mm	SOT340-1

BLOCK DIAGRAM

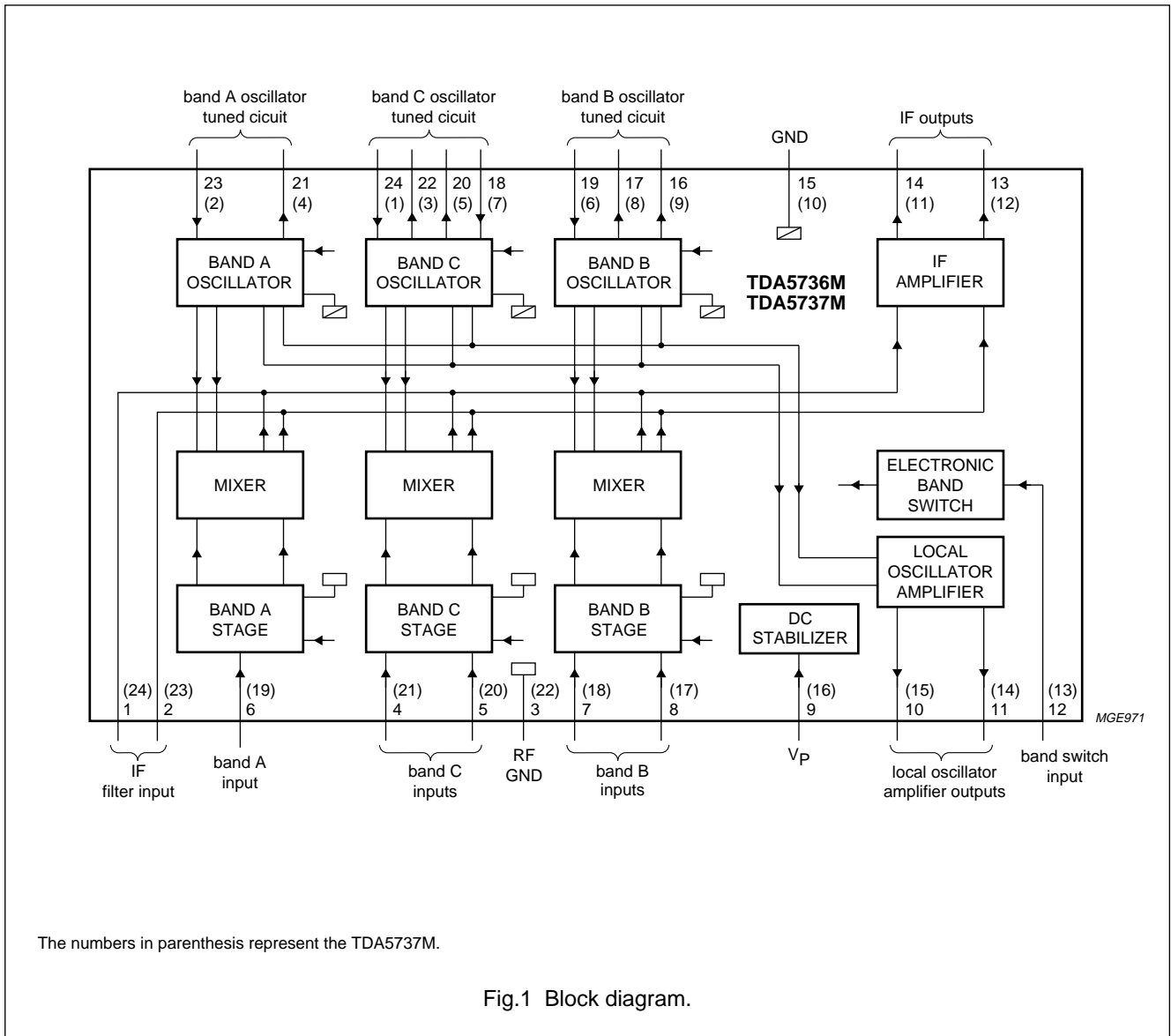

5 V VHF, hyperband and UHF mixer/oscillators for TV and VCR 3-band tuners

TDA5736; TDA5737

PINNING

SYMBOL	PIN		DESCRIPTION
	TDA5736	TDA5737	
IFIN1	1	24	IF filter input 1
IFIN2	2	23	IF filter input 2
RFGND	3	22	ground for RF inputs
CIN1	4	21	band C input 1
CIN2	5	20	band C input 2
AIN	6	19	band A input
BIN1	7	18	band B input 1
BIN2	8	17	band B input 2
V _P	9	16	supply voltage
LOOUT1	10	15	local oscillator amplifier output 1
LOOUT2	11	14	local oscillator amplifier output 2
BS	12	13	band switch input
IFOUT1	13	12	IF amplifier output 1
IFOUT2	14	11	IF amplifier output 2
GND	15	10	ground (0 V)
BOSCOC1	16	9	band B oscillator output collector 1
BOSCOC2	17	8	band B oscillator output collector 2
COSCIB1	18	7	band C oscillator input base 1
BOSCIB	19	6	band B oscillator input base
COSCOC1	20	5	band C oscillator output collector 1
AOSCOC	21	4	band A oscillator output collector
COSCOC2	22	3	band C oscillator output collector 2
AOSCIB	23	2	band A oscillator input base
COSCIB2	24	1	band C oscillator input base 2

5 V VHF, hyperband and UHF mixer/oscillators for TV and VCR 3-band tuners

TDA5736; TDA5737

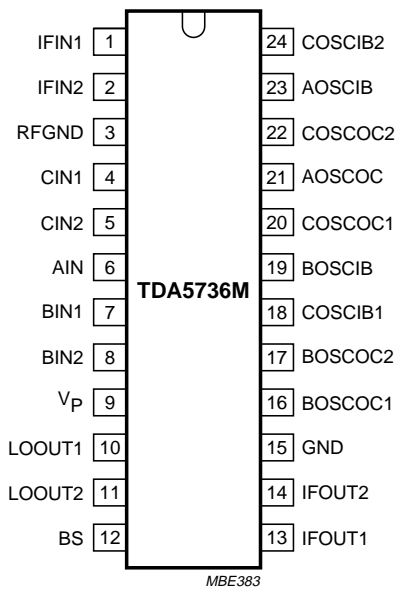

Fig.2 Pin configuration (TDA5736M).

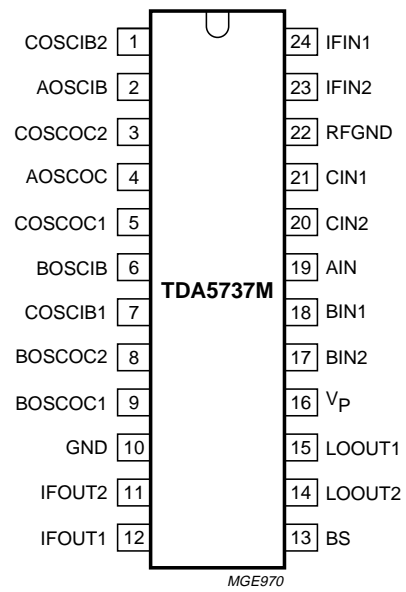

Fig.3 Pin configuration (TDA5737M).

5 V VHF, hyperband and UHF mixer/oscillators for TV and VCR 3-band tuners

TDA5736; TDA5737

LIMITING VALUES

In accordance with the Absolute Maximum Rating System (IEC 134).

SYMBOL	PARAMETER	MIN.	MAX.	UNIT
V_P	supply voltage	-0.3	+7.0	V
V_{SW}	switching voltage	-0.3	+7.0	V
$V_{n(max)}$	maximum voltage on each pin with a 22 k Ω resistor connected in series	-	35	V
I_O	output current of each pin to ground	-	-10	mA
$t_{sc(max)}$	maximum short-circuit time (all pins)	-	10	s
T_{stg}	IC storage temperature	-55	+150	$^{\circ}$ C
T_{amb}	operating ambient temperature	-20	+80	$^{\circ}$ C
T_j	junction temperature	-	+150	$^{\circ}$ C

HANDLING

Human Body Model:

- For TDA5736 GND (15), RFGND (3), V_P (9) separate
- For TDA5737 GND (10), RFGND (22), V_P (16) separate.

All pins withstand 2000 V in accordance with the "UZW-BO/FQ-A302". Philips specification equivalent to the "MIL-STD-883C" category B (2000 V) except pins 16 and 17 (8 and 9 for the TDA5737) which withstand 1000 V; $R = 1500 \Omega$, $C = 100 \text{ pF}$.

Machine Model:

- For TDA5736 GND (15), RFGND (3), V_P (9) separate
- For TDA5737 GND (10), RFGND (22), V_P (16) separate.

All pins withstand 200 V in accordance with the "UZW-BO/FQ-B302", Philips specification (revision of: Nov. 6th, 1990) except pins 16 and 17 (8 and 9 for the TDA5737) which withstand 100 V; $R = 0 \Omega$, $C = 200 \text{ pF}$.

THERMAL CHARACTERISTICS

SYMBOL	PARAMETER	CONDITIONS	VALUE	UNIT
$R_{th\ j-a}$	thermal resistance from junction to ambient	in free air	120	K/W

5 V VHF, hyperband and UHF mixer/oscillators for TV and VCR 3-band tuners

TDA5736; TDA5737

CHARACTERISTICS

$V_P = 5\text{ V}$; $T_{\text{amb}} = 25\text{ °C}$; measured in circuit of Fig.17; unless otherwise specified.

SYMBOL	PARAMETER	CONDITIONS	MIN.	TYP.	MAX.	UNIT
Supply						
V_P	supply voltage		4.5	5.0	5.5	V
I_P	supply current		42	50	58	mA
V_{SW}	switching voltage depending on supply voltage V_P	band A; note 1	0	–	$0.18V_P$	V
		band B; note 1	$0.26V_P$	–	$0.47V_P$	V
		band C; note 1	$0.55V_P$	–	V_P	V
I_{SW}	switching current	band A; note 1	–	–	2	μA
		band B; note 1	–	–	10	μA
		band C; note 1	–	–	25	μA
Band A mixer (including IF amplifier)						
f_{RF}	frequency range	note 2	41	–	171	MHz
G_v	voltage gain	$f_{\text{RF}} = 50\text{ MHz}$; see Fig.4; note 3	20.5	23.0	25.5	dB
		$f_{\text{RF}} = 170\text{ MHz}$; see Fig.4; note 3	20.5	23.0	25.5	dB
NF	noise figure	$f_{\text{RF}} = 50\text{ MHz}$; see Figs.5 and 6	–	7.5	9	dB
		$f_{\text{RF}} = 170\text{ MHz}$; see Figs.5 and 6	–	9	10	dB
V_o	output voltage level causing 1% cross modulation in channel	$f_{\text{RF}} = 50\text{ MHz}$; see Fig.7	115	118	–	$\text{dB}\mu\text{V}$
		$f_{\text{RF}} = 170\text{ MHz}$; see Fig.7	113	116	–	$\text{dB}\mu\text{V}$
V_i	input voltage level causing 10 kHz pulling in channel	$f_{\text{RF}} = 170\text{ MHz}$; note 4	96	100	–	dBmV
g_{os}	optimum source conductance for noise figure	$f_{\text{RF}} = 50\text{ MHz}$	–	0.5	–	mS
		$f_{\text{RF}} = 170\text{ MHz}$	–	1.1	–	mS
Y_i	input admittance	$f_{\text{RF}} = 50\text{ to }170\text{ MHz}$; see Fig.12	–	0.3	–	mS
C_i	input capacitance	$f_{\text{RF}} = 50\text{ to }170\text{ MHz}$; see Fig.12	–	1.9	–	pF
Band A oscillator						
f_{osc}	frequency range	$0.45\text{ V} < V_t < 28\text{ V}$; notes 1 and 5	80	–	210	MHz
f_{shift}	frequency shift	$\Delta V_P = 5\%$; note 6	–	–	53	kHz
f_{drift}	frequency drift with no compensation	$\Delta T = 25\text{ °C}$; NP0 capacitors; note 7	–	–	650	kHz
		5 s to 15 mins after switch on; NP0 capacitors; note 8	–	–	250	kHz
	frequency drift with compensation	$\Delta T = 25\text{ °C}$; notes 7 and 9; see Fig.18	–	–	500	kHz
V_{ripple}	ripple susceptibility of supply voltage (peak-to-peak value)	$f_{\text{osc}} = 80\text{ MHz}$; $4.75\text{ V} < V_P < 5.25\text{ V}$; see Fig.8	20	–	–	mV
		$f_{\text{osc}} = 210\text{ MHz}$; $4.75\text{ V} < V_P < 5.25\text{ V}$; see Fig.8	20	–	–	mV
Φ_N	phase noise	measured at the IF output at 10 kHz offset; $V_o = 105\text{ dB}\mu\text{V}$	81	–	–	dBc/Hz

5 V VHF, hyperband and UHF mixer/oscillators for TV and VCR 3-band tuners

TDA5736; TDA5737

SYMBOL	PARAMETER	CONDITIONS	MIN.	TYP.	MAX.	UNIT
Band B mixer (including IF amplifier)						
f_{RF}	frequency range	note 2	166	–	451	MHz
G_v	voltage gain	$f_{RF} = 170$ MHz; see Fig.9; note 3	31	34	37	dB
		$f_{RF} = 450$ MHz; see Fig.9; note 3	31	34	37	dB
N	noise figure (not corrected for image)	$f_{RF} = 170$ MHz; see Fig.10	–	8	10	dB
		$f_{RF} = 450$ MHz; see Fig.10	–	8	10	dB
V_o	output voltage level causing 1% cross modulation in channel	$f_{RF} = 170$ MHz; see Fig.7	114	117	–	dB μ V
		$f_{RF} = 450$ MHz; see Fig.7	112	115	–	dB μ V
V_i	input voltage level causing 10 kHz pulling in channel	$f_{RF} = 450$ MHz; note 4	83	87	–	dB μ V
Z_i	input impedance ($R_s + jL_s\omega$)	$f_{RF} = 170$ to 450 MHz; see Fig.13	–	23	–	Ω
		$f_{RF} = 170$ to 450 MHz; see Fig.13	–	9	–	nH
Band B oscillator						
f_{osc}	frequency range	$0.45 V < V_t < 28 V$; notes 1 and 5	205	–	490	MHz
f_{shift}	frequency shift	$\Delta V_p = 5\%$; note 6	–	–	53	kHz
f_{drift}	frequency drift with no compensation	$\Delta T = 25$ °C; NP0 capacitors; note 7	–	–	2000	kHz
		5 s to 15 mins after switch on; NP0 capacitors; note 8	–	–	750	kHz
	frequency drift with compensation	$\Delta T = 25$ °C; notes 7 and 9; see Fig.18	–	–	750	kHz
		5 s to 15 mins after switch on; notes 8 and 9; see Fig.18	–	–	300	kHz
V_{ripple}	ripple susceptibility of supply voltage (peak-to-peak value)	$f_{osc} = 250$ MHz; $4.75 V < V_p < 5.25 V$; see Fig.8	20	–	–	mV
		$f_{osc} = 490$ MHz; $4.75 V < V_p < 5.25 V$; see Fig.8	20	–	–	mV
Φ_N	phase noise	measured at the IF output at 10 kHz offset; $V_o = 105$ dBmV	81	–	–	dBc/Hz
Band C Mixer (including IF amplifier)						
f_{RF}	frequency range	note 2	446	–	861	MHz
G_v	voltage gain	$f_{RF} = 450$ MHz; see Fig.9; note 3	31	34	37	dB
		$f_{RF} = 860$ MHz; see Fig.9; note 3	31	34	37	dB
N	noise figure (not corrected for image)	$f_{RF} = 450$ MHz; see Fig.10	–	9	11	dB
		$f_{RF} = 860$ MHz; see Fig.10	–	9	11	dB
V_o	output voltage level causing 1% cross modulation in channel	$f_{RF} = 450$ MHz; see Fig.7	112	115	–	dB μ V
		$f_{RF} = 860$ MHz; see Fig.7	112	115	–	dB μ V
V_i	input voltage level causing 10 kHz pulling in channel	$f_{RF} = 860$ MHz; note 4	91	95	–	dB μ V
Z_i	input impedance ($R_s + jL_s\omega$)	$f_{RF} = 450$ to 860 MHz; see Fig.14	–	28	–	Ω
		$f_{RF} = 450$ to 860 MHz; see Fig.14	–	10	–	nH

5 V VHF, hyperband and UHF mixer/oscillators for TV and VCR 3-band tuners

TDA5736; TDA5737

SYMBOL	PARAMETER	CONDITIONS	MIN.	TYP.	MAX.	UNIT
Band C oscillator						
f_{osc}	frequency range	$0.45 \text{ V} < V_t < 28 \text{ V}$; notes 1 and 5	485	–	900	MHz
f_{shift}	frequency shift	$\Delta V_P = 5\%$; note 6	–	–	53	kHz
f_{drift}	frequency drift with no compensation	$\Delta T = 25 \text{ }^\circ\text{C}$; NP0 capacitors; note 7	–	–	2800	kHz
		5 s to 15 mins after switch on; NP0 capacitors; note 8	–	–	700	kHz
	frequency drift with compensation	$\Delta T = 25 \text{ }^\circ\text{C}$; notes 7 and 9; see Fig.18	–	–	1000	kHz
V_{ripple}	ripple susceptibility of supply voltage (peak to peak value)	$f_{osc} = 485 \text{ MHz}$; $4.75 \text{ V} < V_P < 5.25 \text{ V}$; see Fig.8	20	–	–	mV
		$f_{osc} = 900 \text{ MHz}$; $4.75 \text{ V} < V_P < 5.25 \text{ V}$; see Fig.8	18	–	–	mV
Φ_N	phase noise	measured at the IF output at 10 kHz offset; $V_o = 105 \text{ dB}\mu\text{V}$	81	–	–	dBc/Hz
LO output						
Z_o	output admittance ($Y_P + j\omega C_P$)	$Y_P = 80 \text{ MHz}$; see Fig.12	–	2.5	–	mS
		$Y_P = 900 \text{ MHz}$; see Fig.12	–	5	–	mS
		C_P ; see Fig.12	–	0.9	–	pF
V_o	output voltage	$R_L = 50 \text{ } \Omega$; $0 < V_t < 35 \text{ V}$	80	91	100	dB μV
SRF	spurious signal on LO output with respect to LO output signal	$R_L = 50 \text{ } \Omega$; $0.2 \text{ V} < V_t < 35 \text{ V}$; notes 1 and 10	–	–	–10	dB
HLO	LO signal harmonics with respect to LO signal	$R_L = 50 \text{ } \Omega$; $0 < V_t < 35 \text{ V}$; note 1	–	–	–10	dB
IF amplifier						
S_{22}	output reflection coefficient	magnitude; see Fig.15	–	–16	–	dB
		phase; see Fig.15	–	12	–	deg.
Z_o	output impedance ($R_s + jL_s\omega$)	R_s	–	67	–	Ω
		L_s	–	20	–	nH

Notes

- $-20 \text{ }^\circ\text{C} < T_{amb} < +80 \text{ }^\circ\text{C}$; $4.5 \text{ V} < V_P < 5.5 \text{ V}$.
- The RF frequency range is defined by the oscillator frequency range and the intermediate frequency.
- The gain is defined as the transducer gain (measured in Fig.17) plus the voltage transformation ratio of L7 to L8 (10 : 2, 15.4 dB including transformer loss).
- The input level causing 10 kHz frequency detuning at the LO output. $f_{osc} = f_{RF} + 33.4 \text{ MHz}$.
- Limits are related to the tank circuits used in Fig.17. Frequency bands may be adjusted by the choice of external components.
- The frequency shift is defined as the change in oscillator frequency when the supply voltage varies from $V_P = 5$ to 4.75 V and from $V_P = 5$ to 5.25 V .

5 V VHF, hyperband and UHF mixer/oscillators for TV and VCR 3-band tuners

TDA5736; TDA5737

7. The frequency drift is defined as the change in oscillator frequency when the ambient temperature varies from $T_{amb} = 25$ to 0 °C and from $T_{amb} = 25$ to 50 °C.
8. Switch-on drift is defined as the change in oscillator frequency between 5 s and 15 mins after switch on.
9. With thermal compensation, the capacitors of the tank circuits have the following temperature coefficients:
 - a) In band A: C1, C6 and C8 are N750.
 - b) In band B: C4, C11, C12, C13 and C36 are N750.
 - c) In band C: C5, C7, C9 and C10 are N750; C2 is N220 and C3 is NP0.
10. SRF: spurious signal on LO with respect to LO output signal;
 - a) RF level = 120 dB μ V at $f_{RF} < 180$ MHz.
 - b) RF level = 107.5 dB μ V at $f_{RF} = 180$ to 225 MHz.
 - c) RF level = 97 dB μ V at $f_{RF} = 225$ to 860 MHz.

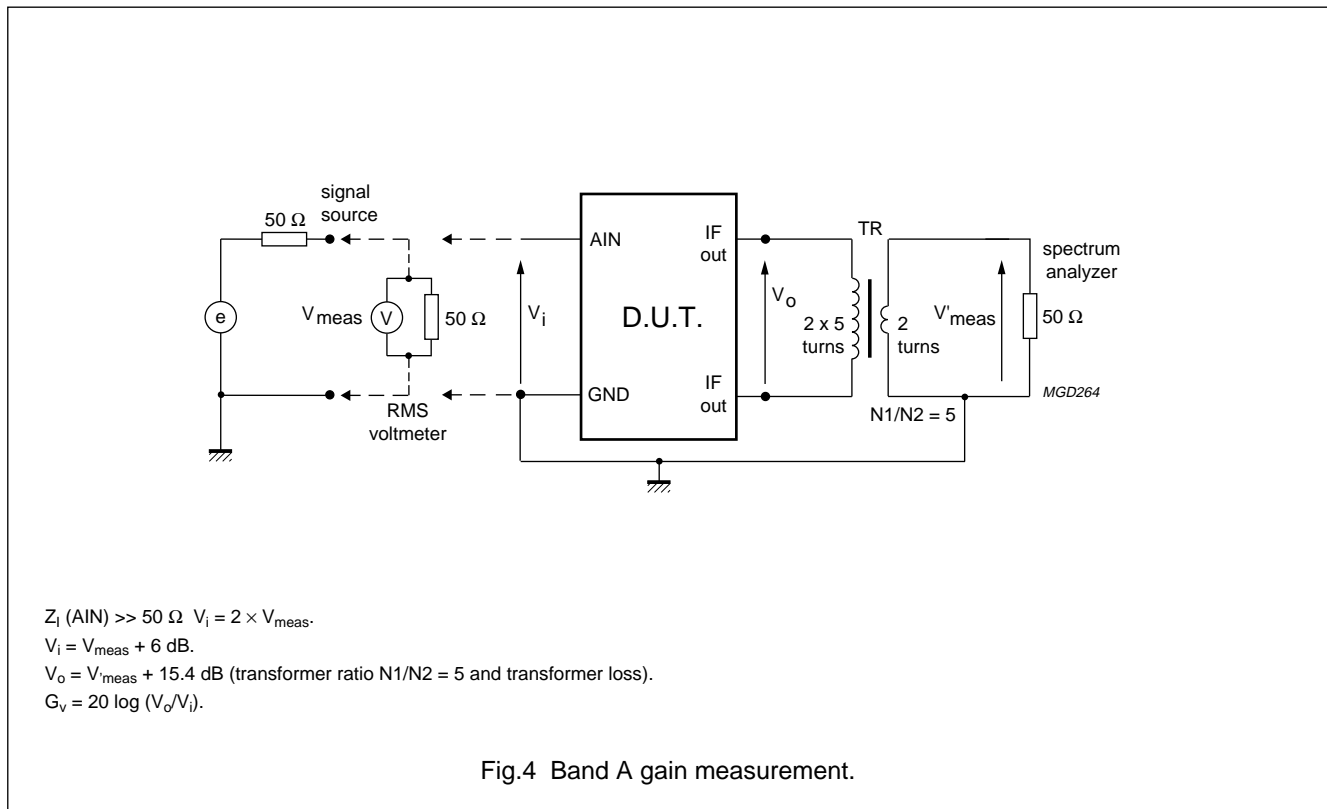
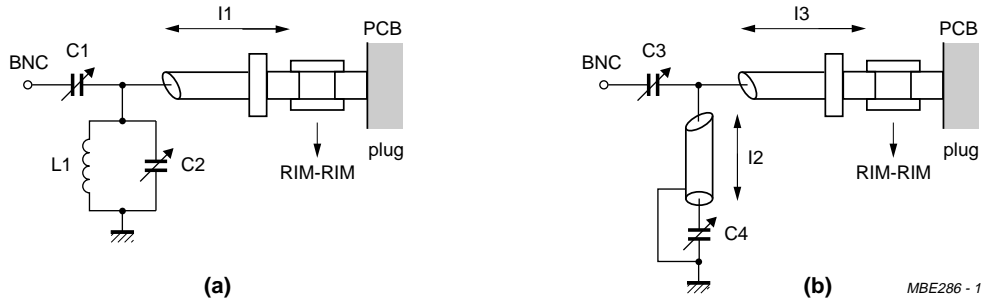

Fig.4 Band A gain measurement.

5 V VHF, hyperband and UHF mixer/oscillators for TV and VCR 3-band tuners

TDA5736; TDA5737



(a) For $f_{RF} = 50$ MHz:
 mixer A frequency response measured = 57 MHz, loss = 0 dB
 image suppression = 16 dB.
 C1 = 9 pF
 C2 = 15 pF
 L1 = 7 turns (diam. = 5.5 mm, wire diam. = 0.5 mm)
 I1 = semi rigid cable (RIM): 5 cm long (semi rigid cable (RIM);
 33 dB/100 m; 50 Ω ; 96 pF/m).

(b) For $f_{RF} = 150$ MHz:
 mixer A frequency response measured = 150.3 MHz, loss = 1.3 dB
 image suppression = 13 dB.
 C3 = 5 pF
 C4 = 25 pF
 I2 = semi rigid cable (RIM): 30 cm long
 I3 = semi rigid cable (RIM): 5 cm long (semi rigid cable (RIM);
 33 dB/100 m; 50 Ω ; 96 pF/m).

Fig.5 Input circuit for optimum noise figure in band A.

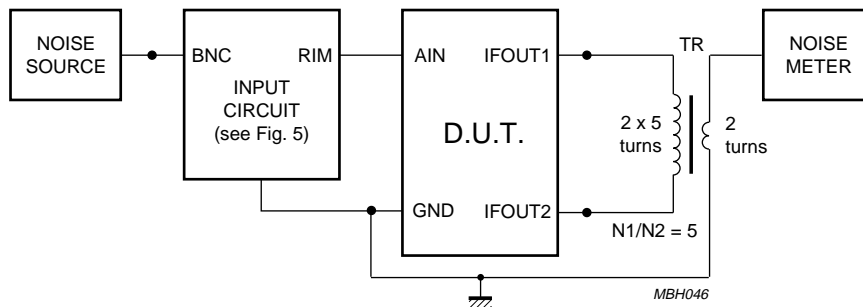

$NF = NF_{meas} - \text{loss (input circuit) dB.}$

Fig.6 Noise figure measurement in band A.

5 V VHF, hyperband and UHF mixer/oscillators for TV and VCR 3-band tuners

TDA5736; TDA5737

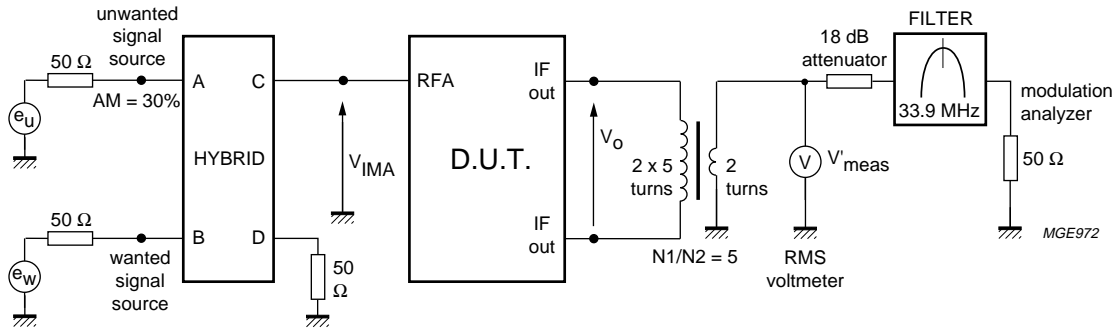

$V'_{meas} = V_o - 15.4 \text{ dB}$ (transformer ratio $N1/N2 = 5$ and transformer loss).
 Wanted output signal at $f_{RFW} = 50 \text{ MHz}$ (170 MHz); $V_{ow} = 80 \text{ dB}\mu\text{V}$.
 We measure the level of the unwanted signal V_{ou} causing 1% AM modulation in the wanted output signal; $f_{RFU} = 45.5 \text{ MHz}$ (165.5 MHz);
 $f_{osc} = 83.9 \text{ MHz}$ (203.9 MHz).
 $V_{ou} = V'_{meas} + 15.4 \text{ dB}$.
 Filter characteristics: $f_c = 33.9 \text{ MHz}$, $f_{-3\text{dB}\text{BW}} = 1 \text{ MHz}$; $f_{-30\text{dB}\text{BW}} = 2.3 \text{ MHz}$.

Fig.7 Cross modulation measurement in band A.

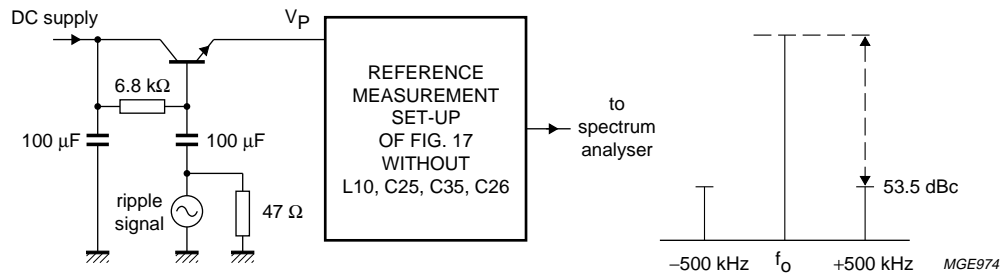

The ripple susceptibility is defined as the level of a signal added to the supply voltage causing sidebands in the LO output at 53.5 dBc. This signal has a frequency between 20 Hz and 500 kHz.

Fig.8 Ripple susceptibility.

5 V VHF, hyperband and UHF mixer/oscillators for TV and VCR 3-band tuners

TDA5736; TDA5737

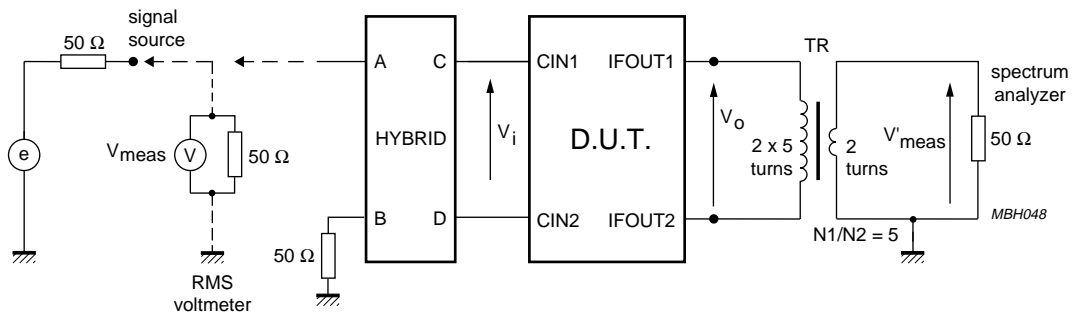

$loss_{(hybrid)} = 1 \text{ dB.}$
 $V_i = V_{meas} - loss_{(hybrid)}$
 $V_o = V'_{meas} + 15.4 \text{ dB (transformer ratio } N1/N2 \text{ and transformer loss).}$
 Voltage gain for band B and C = $20 \log (V_o/V_i)$.

Fig.9 Gain measurement in bands B and C.

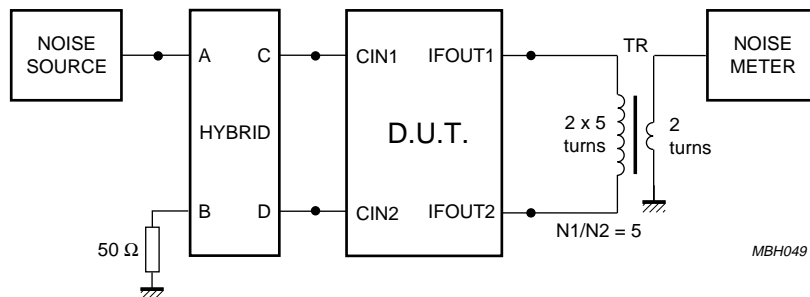

Loss of the hybrid: 1 dB.
 $NF = NF_{meas} - loss \text{ of the hybrid.}$

Fig.10 Noise figure measurement in bands B and C.

5 V VHF, hyperband and UHF mixer/oscillators for TV and VCR 3-band tuners

TDA5736; TDA5737

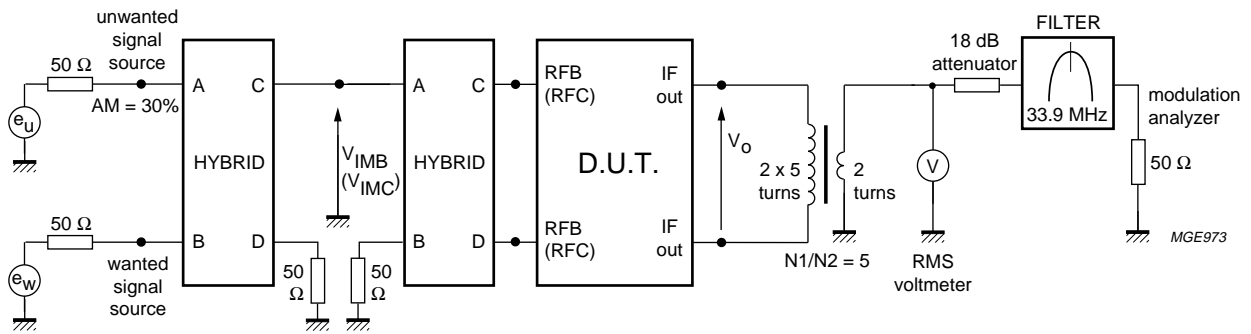

$V'_{meas} = V_o - 15.4 \text{ dB}$ (transformer ratio $N1/N2 = 5$ and transformer loss).
 Wanted output signal at $f_{RFW} = 170$ or 450 MHz (450 or 860 MHz); $V_{ow} = 70 \text{ dB}\mu\text{V}$.
 We measure the level of the unwanted signal V_{ou} causing 1% AM modulation in the wanted output signal;
 $f_{RFU} = 165.5$ or 445.5 MHz (445.5 or 855.5 MHz); $f_{OSC} = 203.9$ or 483.9 MHz (483.9 or 893.9 MHz).
 $V_{ou} = V'_{meas} + 15.4 \text{ dB}$.
 Filter characteristics: $f_c = 33.9 \text{ MHz}$, $f_{-3\text{dB}\text{BW}} = 1 \text{ MHz}$; $f_{-30\text{dB}\text{BW}} = 2.3 \text{ MHz}$.

Fig.11 Cross modulation measurement in bands B and C.

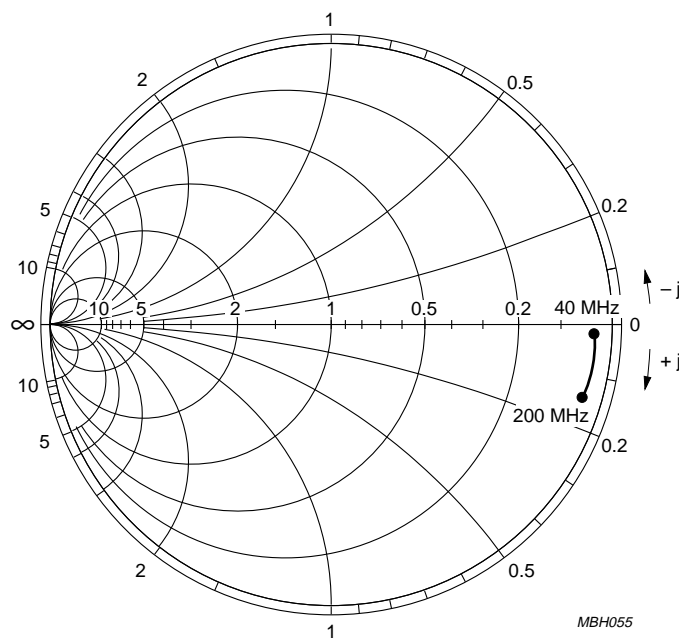

Fig.12 Input admittance (S_{11}) of the band A mixer input (40 to 200 MHz); $Y_o = 20 \text{ mS}$.

5 V VHF, hyperband and UHF mixer/oscillators for TV and VCR 3-band tuners

TDA5736; TDA5737

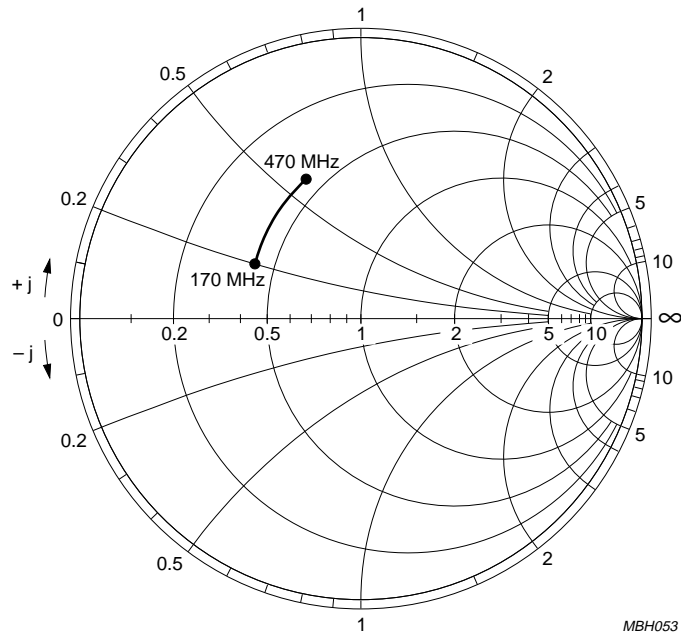

Fig.13 Input impedance (S_{11}) of the band B mixer input (170 to 470 MHz); $Z_o = 50 \Omega$.

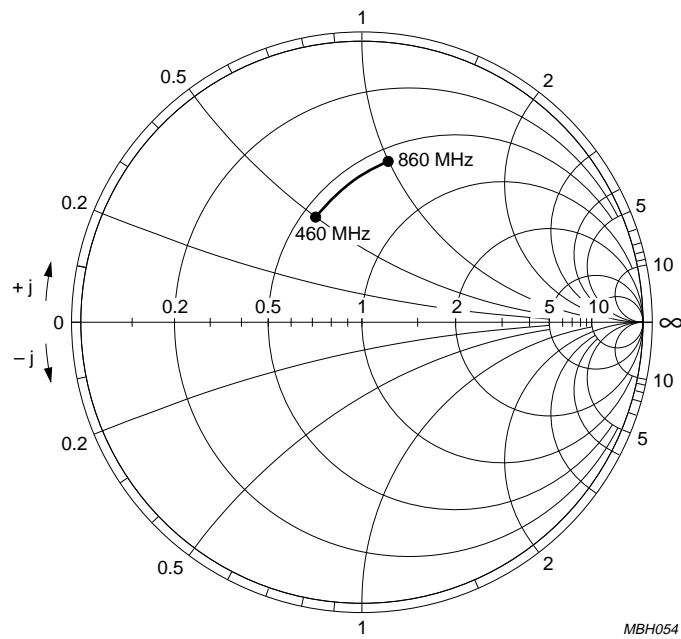

Fig.14 Input impedance (S_{11}) of the band C mixer input (460 to 860 MHz); $Z_o = 50 \Omega$.

5 V VHF, hyperband and UHF mixer/oscillators for TV and VCR 3-band tuners

TDA5736; TDA5737

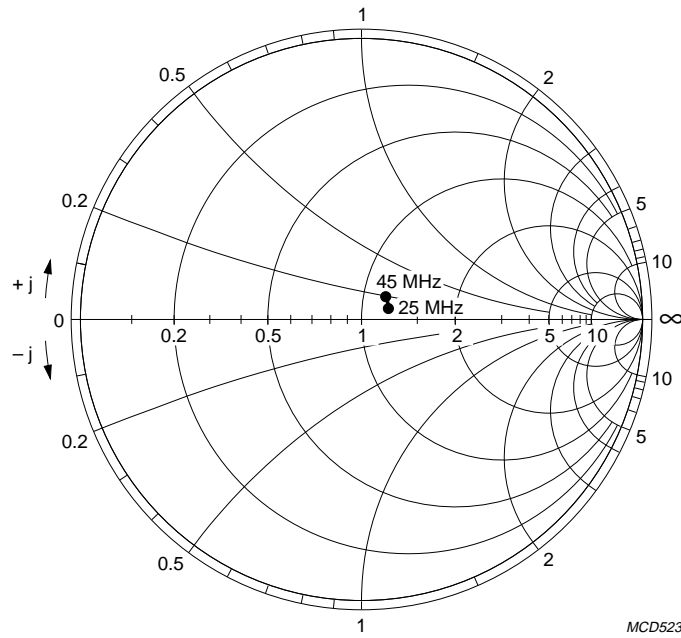

Fig.15 Input impedance (S_{22}) of the IF amplifier (25 to 45 MHz); $Z_o = 100 \Omega$.

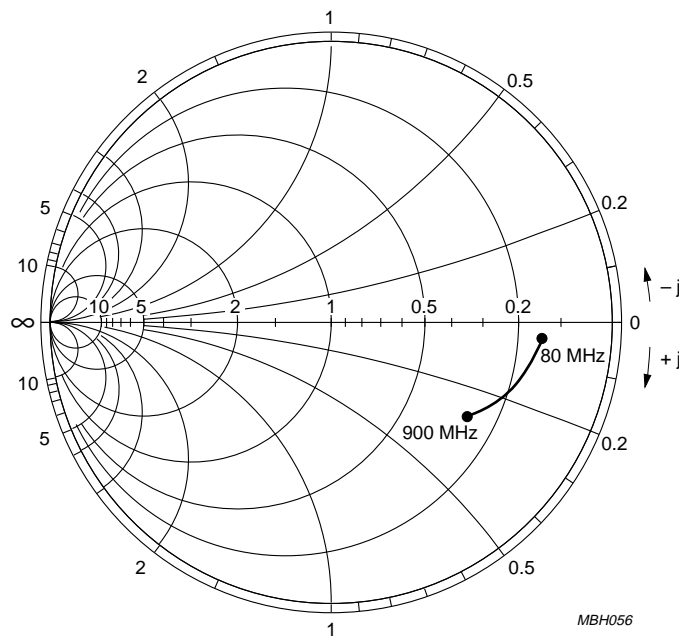
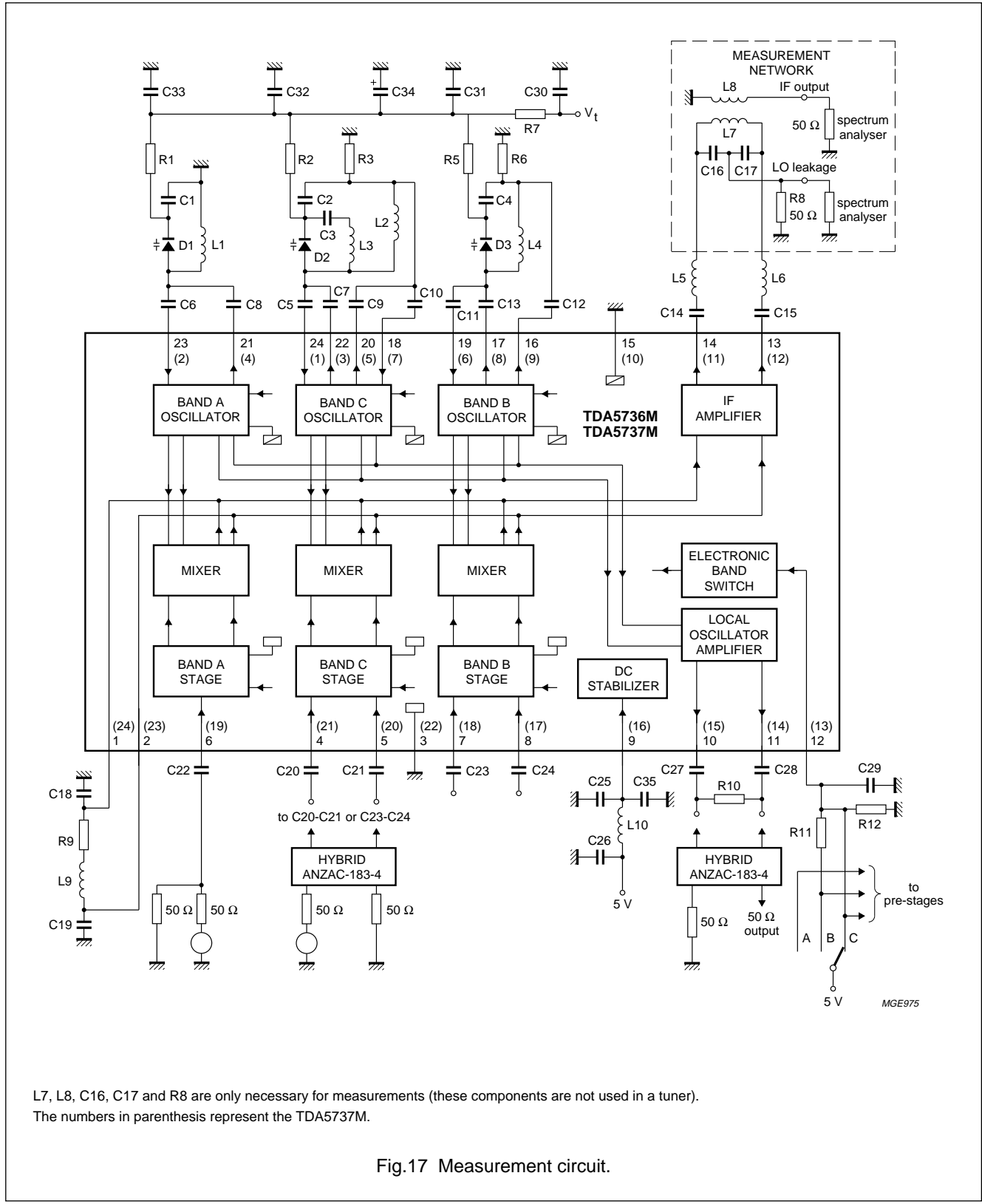

Fig.16 Input impedance (S_{22}) of the LO amplifier (80 to 900 MHz); $Y_o = 20 \text{ mS}$.

5 V VHF, hyperband and UHF mixer/oscillators for TV and VCR 3-band tuners

TDA5736; TDA5737

APPLICATION INFORMATION



L7, L8, C16, C17 and R8 are only necessary for measurements (these components are not used in a tuner).
 The numbers in parenthesis represent the TDA5737M.

Fig.17 Measurement circuit.

5 V VHF, hyperband and UHF mixer/oscillators for TV and VCR 3-band tuners

TDA5736; TDA5737

Table 1 Capacitors of Fig.17
(all SMD and NP0 except C34 and C35)

NUMBER	VALUE
C1	82 pF
C2	5.6 pF
C3	100 pF
C4	82 pF
C5	1 pF
C6	2 pF
C7	2 pF
C8	2 pF
C9	2 pF
C10	1 pF
C11	3.3 pF
C12	3.3 pF
C13	4.7 pF
C14	1 nF
C15	1 nF
C16	39 pF
C17	39 pF
C18	68 pF
C19	68 pF
C20	1 nF
C21	1 nF
C22	1 nF
C23	1 nF
C24	1 nF
C25	2.2 nF
C26	1 nF
C27	1 nF
C28	1 nF
C29	1 nF
C30	1 nF
C31	1 nF
C32	1 nF
C33	1 nF
C34	2.2 μ F, 40 V electrolytic
C35	4.7 nF

Table 2 Resistors of Fig.17 (all SMD)

NUMBER	VALUE
R1	47 k Ω
R2	22 k Ω
R3	22 k Ω
R5	27 k Ω
R6	27 k Ω
R7	10 k Ω
R8	50 Ω
R9	4.7 Ω
R10	100 Ω
R11	27 k Ω
R12	15 k Ω

Table 3 Diodes, coils and transformers of Fig.17

NUMBER	VALUE
Diodes	
D1	BB132
D2	BB134
D3	BB133
Coils⁽¹⁾	
L1	7.5 t (\varnothing 3 mm)
L2	2.5 t (\varnothing 3.5 mm)
L3	1.5 t (\varnothing 2.5 mm)
L4	2.5 t (\varnothing 3 mm)
L5	5.5 t (\varnothing 2.5 mm)
L6	5.5 t (\varnothing 2.5 mm)
L9	12.5 t (\varnothing 5 mm)
L10	2.2 μ H (choke coil)
Transformers⁽²⁾	
L7	2 \times 5 t
L8	2 t

Notes

1. Wire size for L1 to L6 is 0.4 mm.
2. Coil type: TOKO 7kL.

5 V VHF, hyperband and UHF mixer/oscillators for TV and VCR 3-band tuners

TDA5736; TDA5737

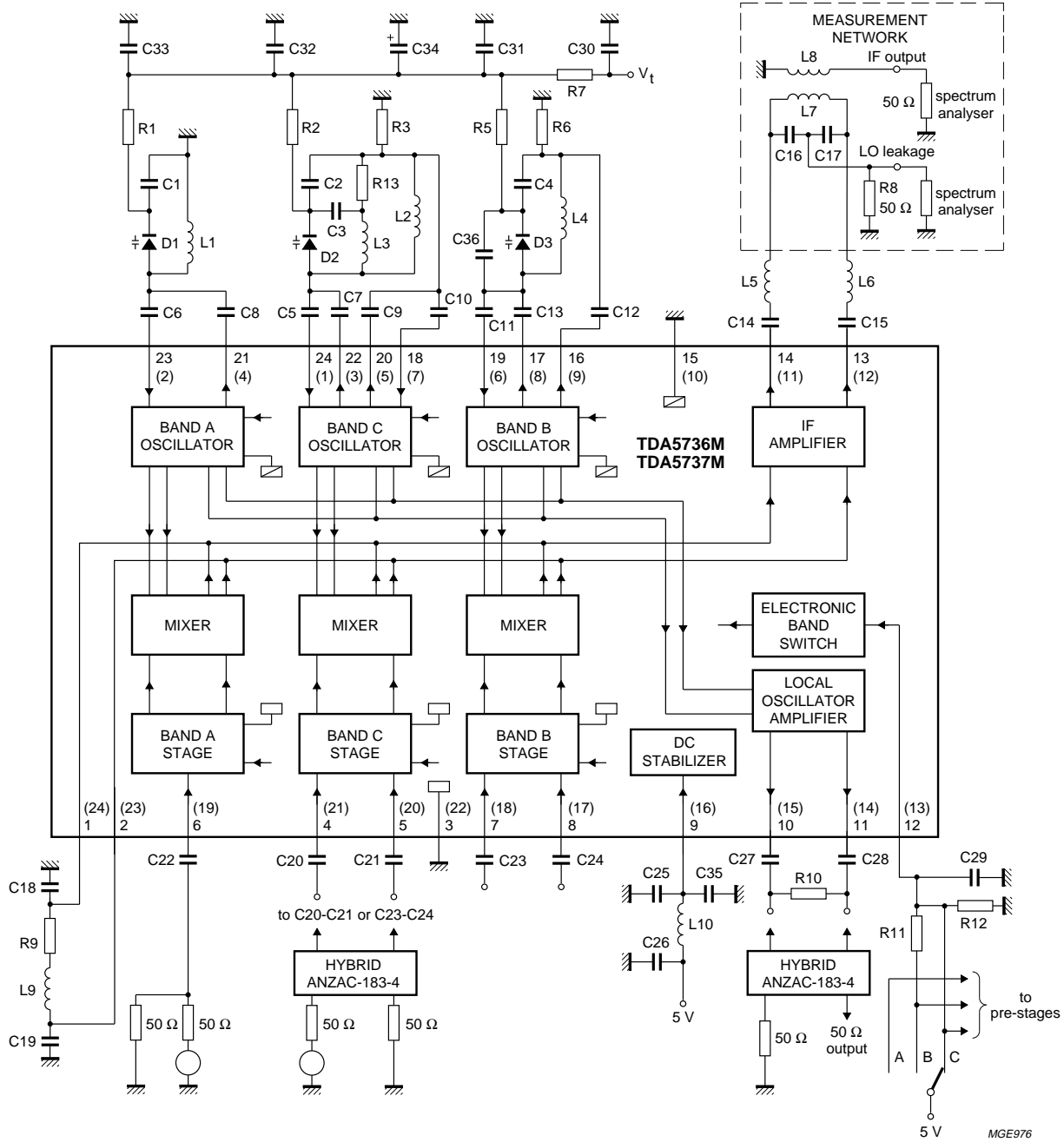

L7, L8, C16, C17 and R8 are only necessary for measurements (these components are not used in a tuner).
 The numbers in parenthesis represent the TDA5737M.

Fig.18 Measurement circuit with thermal compensation.

5 V VHF, hyperband and UHF mixer/oscillators for TV and VCR 3-band tuners

TDA5736; TDA5737

Table 4 Capacitors of Fig.18 (all SMD except C34)

NUMBER	VALUE
C1	62 pF
C2	6 pF
C3	100 pF
C4	68 pF
C5	1.2 pF
C6	2 pF
C7	1.2 pF
C8	2 pF
C9	1.5 pF
C10	1.5 pF
C11	3 pF
C12	3 pF
C13	4.3 pF
C14	1 nF
C15	1 nF
C16	39 pF
C17	39 pF
C18	68 pF
C19	68 pF
C20	1 nF
C21	1 nF
C22	1 nF
C23	1 nF
C24	1 nF
C25	2.2 nF
C26	1 nF
C27	1 nF
C28	1 nF
C29	1 nF
C30	1 nF
C31	1 nF
C32	1 nF
C33	1 nF
C34	2.2 μ F; 40 V electrolytic
C35	4.7 nF
C36	0.5 pF

Table 5 Resistors of Fig.18 (all SMD)

NUMBER	VALUE
R1	47 k Ω
R2	22 k Ω
R3	22 k Ω
R5	27 k Ω
R6	27 k Ω
R7	10 k Ω
R8	50 Ω
R9	4.7 Ω
R10	100 Ω
R11	27 k Ω
R12	15 k Ω
R13	4.7 k Ω

Table 6 Diodes, coils and transformers of Fig.18

NUMBER	VALUE
Diodes	
D1	BB132
D2	BB134
D3	BB133
Coils⁽¹⁾	
L1	7.5 t (\varnothing 3 mm)
L2	2.5 t (\varnothing 2 mm)
L3	2.5 t (\varnothing 2 mm)
L4	2.5 t (\varnothing 2.5 mm)
L5	5.5 t (\varnothing 2.5 mm)
L6	5.5 t (\varnothing 2.5 mm)
L9	12.5 t (\varnothing 5 mm)
L10	2.2 μ H; choke coil
Transformers⁽²⁾	
L7	2 \times 5 turns
L8	2 turns

Notes

- The wire size for L1, L2, L5 and L6 is 0.4 mm.
The wire size for L3 and L4 is 0.5 mm.
- Coil type: TOKO 7kL.

5 V VHF, hyperband and UHF mixer/oscillators for TV and VCR 3-band tuners

TDA5736; TDA5737

INTERNAL PIN CONFIGURATION

SYMBOL	PIN		DESCRIPTION	AVERAGE DC VOLTAGE IN (V) ⁽¹⁾ measured in circuit of Fig.17		
	TDA5736	TDA5737		BAND A	BAND B	BAND C
IFIN1	1	24		3.6	3.6	3.6
IFIN2	2	23		3.6	3.6	3.6
RFGND	3	22		0	0	0
CIN1	4	21		NR	NR	1.0
CIN2	5	20		NR	NR	1.0
AIN	6	19		1.8	NR	NR
BIN1	7	18		NR	1.0	NR
BIN2	8	17		NR	1.0	NR
V _P	9	16	supply voltage	5.0	5.0	5.0

5 V VHF, hyperband and UHF mixer/oscillators for TV and VCR 3-band tuners

TDA5736; TDA5737

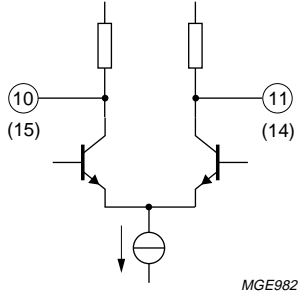
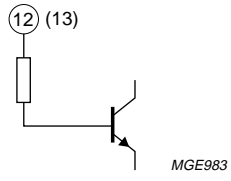
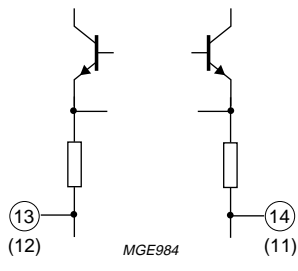
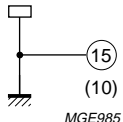
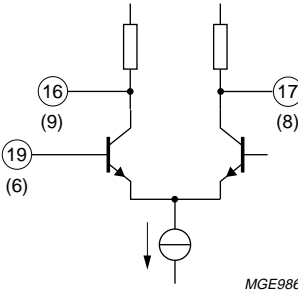
SYMBOL	PIN		DESCRIPTION	AVERAGE DC VOLTAGE IN (V) ⁽¹⁾ measured in circuit of Fig.17		
	TDA5736	TDA5737		BAND A	BAND B	BAND C
LOOUT1	10	15	 <p>MGE982</p>	4.2	NR	NR
LOOUT2	11	14		4.2	NR	NR
BS	12	13	 <p>MGE983</p>	0.0	1.8	5.0
IFOUT1	13	12	 <p>MGE984</p>	2.1	NR	NR
IFOUT2	14	11		2.1	NR	NR
GND	15	10	 <p>MGE985</p>	0.0	0.0	0.0
BOSCOC1	16	9	 <p>MGE986</p>	NR	2.7	NR
BOSCOC2	17	8		NR	2.7	NR
BOSCIB	19	6		NR	2.0	NR

5 V VHF, hyperband and UHF mixer/oscillators for TV and VCR 3-band tuners

TDA5736; TDA5737

SYMBOL	PIN		DESCRIPTION	AVERAGE DC VOLTAGE IN (V) ⁽¹⁾ measured in circuit of Fig.17		
	TDA5736	TDA5737		BAND A	BAND B	BAND C
COSCIB1	18	7	<p>MGE987</p>	NR	NR	2.0
COSCOC1	20	5		NR	NR	2.7
COSCOC2	22	3		NR	NR	2.7
COSCIB2	24	1		NR	NR	2.0
AOSCOC	21	4	<p>MGE988</p>	2.5	NR	NR
AOSCIB	23	2		2.0	NR	NR

Note

1. NR = not relevant.

5 V VHF, hyperband and UHF mixer/oscillators for TV and VCR 3-band tuners

TDA5736; TDA5737

PACKAGE OUTLINE

SSOP24: plastic shrink small outline package; 24 leads; body width 5.3 mm

SOT340-1

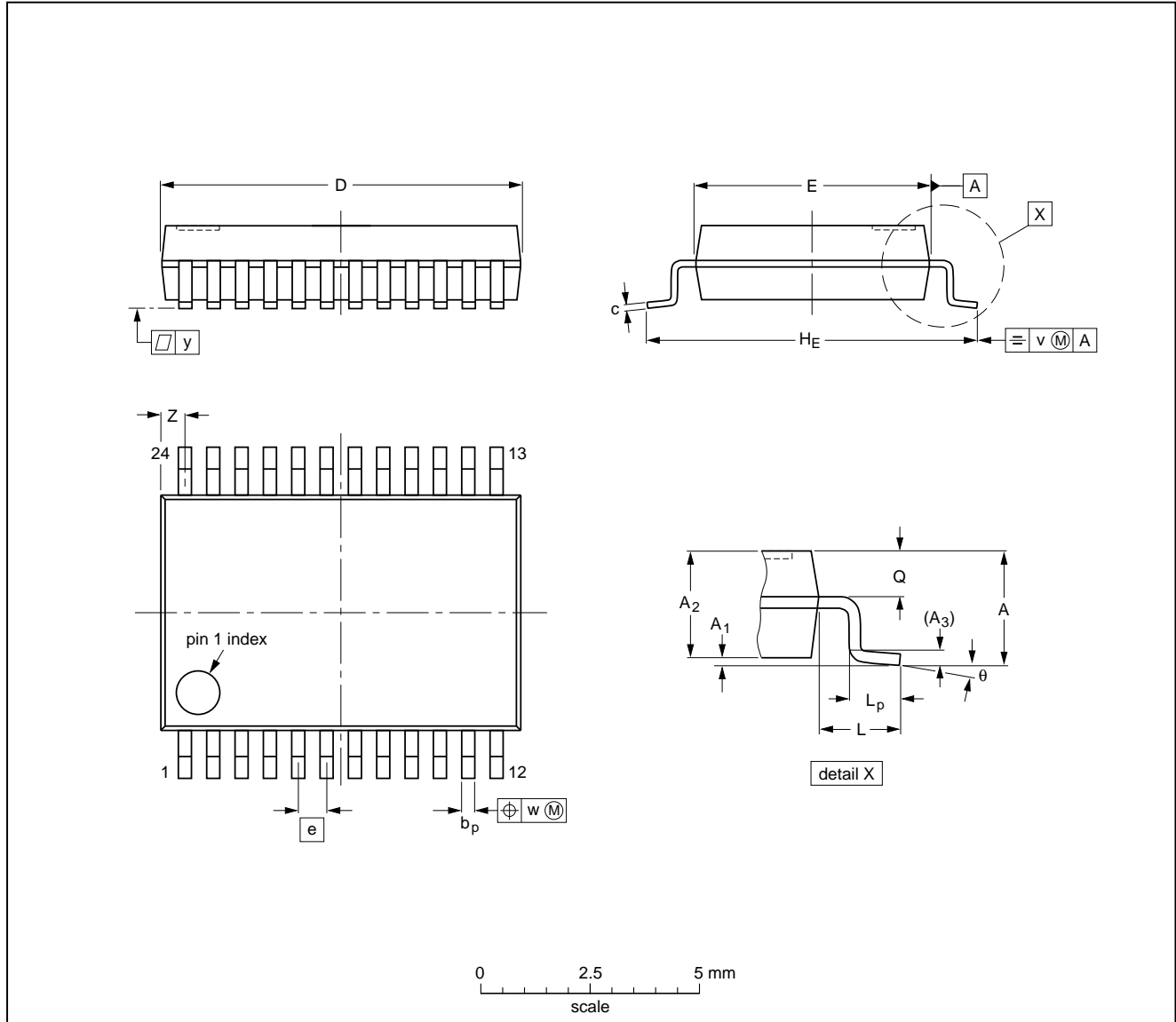

DIMENSIONS (mm are the original dimensions)

UNIT	A max.	A ₁	A ₂	A ₃	b _p	c	D ⁽¹⁾	E ⁽¹⁾	e	H _E	L	L _p	Q	v	w	y	Z ⁽¹⁾	θ
mm	2.0	0.21 0.05	1.80 1.65	0.25	0.38 0.25	0.20 0.09	8.4 8.0	5.4 5.2	0.65	7.9 7.6	1.25	1.03 0.63	0.9 0.7	0.2	0.13	0.1	0.8 0.4	8° 0°

Note

1. Plastic or metal protrusions of 0.20 mm maximum per side are not included.

OUTLINE VERSION	REFERENCES				EUROPEAN PROJECTION	ISSUE DATE
	IEC	JEDEC	EIAJ			
SOT340-1		MO-150AG				93-09-08 95-02-04

5 V VHF, hyperband and UHF mixer/oscillators for TV and VCR 3-band tuners

TDA5736; TDA5737

SOLDERING

Introduction

There is no soldering method that is ideal for all IC packages. Wave soldering is often preferred when through-hole and surface mounted components are mixed on one printed-circuit board. However, wave soldering is not always suitable for surface mounted ICs, or for printed-circuits with high population densities. In these situations reflow soldering is often used.

This text gives a very brief insight to a complex technology. A more in-depth account of soldering ICs can be found in our "IC Package Databook" (order code 9398 652 90011).

Reflow soldering

Reflow soldering techniques are suitable for all SSOP packages.

Reflow soldering requires solder paste (a suspension of fine solder particles, flux and binding agent) to be applied to the printed-circuit board by screen printing, stencilling or pressure-syringe dispensing before package placement.

Several techniques exist for reflowing; for example, thermal conduction by heated belt. Dwell times vary between 50 and 300 seconds depending on heating method. Typical reflow temperatures range from 215 to 250 °C.

Preheating is necessary to dry the paste and evaporate the binding agent. Preheating duration: 45 minutes at 45 °C.

Wave soldering

Wave soldering is **not** recommended for SSOP packages. This is because of the likelihood of solder bridging due to closely-spaced leads and the possibility of incomplete solder penetration in multi-lead devices.

If wave soldering cannot be avoided, the following conditions must be observed:

- **A double-wave (a turbulent wave with high upward pressure followed by a smooth laminar wave) soldering technique should be used.**
- **The longitudinal axis of the package footprint must be parallel to the solder flow and must incorporate solder thieves at the downstream end.**

Even with these conditions, only consider wave soldering SSOP packages that have a body width of 4.4 mm, that is SSOP16 (SOT369-1) or SSOP20 (SOT266-1).

During placement and before soldering, the package must be fixed with a droplet of adhesive. The adhesive can be applied by screen printing, pin transfer or syringe dispensing. The package can be soldered after the adhesive is cured.

Maximum permissible solder temperature is 260 °C, and maximum duration of package immersion in solder is 10 seconds, if cooled to less than 150 °C within 6 seconds. Typical dwell time is 4 seconds at 250 °C.

A mildly-activated flux will eliminate the need for removal of corrosive residues in most applications.

Repairing soldered joints

Fix the component by first soldering two diagonally-opposite end leads. Use only a low voltage soldering iron (less than 24 V) applied to the flat part of the lead. Contact time must be limited to 10 seconds at up to 300 °C. When using a dedicated tool, all other leads can be soldered in one operation within 2 to 5 seconds between 270 and 320 °C.

5 V VHF, hyperband and UHF mixer/oscillators for TV and VCR 3-band tuners

TDA5736; TDA5737

DEFINITIONS

Data sheet status	
Objective specification	This data sheet contains target or goal specifications for product development.
Preliminary specification	This data sheet contains preliminary data; supplementary data may be published later.
Product specification	This data sheet contains final product specifications.
Limiting values	
Limiting values given are in accordance with the Absolute Maximum Rating System (IEC 134). Stress above one or more of the limiting values may cause permanent damage to the device. These are stress ratings only and operation of the device at these or at any other conditions above those given in the Characteristics sections of the specification is not implied. Exposure to limiting values for extended periods may affect device reliability.	
Application information	
Where application information is given, it is advisory and does not form part of the specification.	

LIFE SUPPORT APPLICATIONS

These products are not designed for use in life support appliances, devices, or systems where malfunction of these products can reasonably be expected to result in personal injury. Philips customers using or selling these products for use in such applications do so at their own risk and agree to fully indemnify Philips for any damages resulting from such improper use or sale.