

DATA SHEET

TDA8785

**8-bit high-speed analog-to-digital
converter with gain and offset
controls**

Preliminary specification
File under Integrated Circuits, IC02

1996 Jan 17

8-bit high-speed analog-to-digital converter with gain and offset controls

TDA8785

FEATURES

- 8-bit analog-to-digital converter (ADC)
- 8-bit digital-to-analog converter (DAC)
- Sampling rate up to 30 Msp/s for both ADC and DAC
- Binary or two's complement 3-state TTL outputs
- TTL compatible inputs and outputs
- 100 MHz variable gain amplifier (0 to 20 dB) externally controlled
- All analog inputs and outputs are differential (can also be used in single-ended format)
- Analog input signal from 0.1 to 1.0 V (p-p) differential
- Offset amplifier with:
 - slow offset control (± 250 mV)
 - fast offset control (± 500 mV) eventually driven by internal DAC
- ADC output code of 8 (typ.) when analog input signal and offset correction inputs are 0 V

- Gain, slow offset control inputs and DAC output swing of 1.5 V (p-p) range (2.75 ± 0.75 V)
- 2.75 V reference voltage
- Internal references for ADC and DAC.

GENERAL DESCRIPTION

The TDA8785 is an 8-bit analog-to-digital converter with gain and offset controls for the input signal. An internal 8-bit DAC provides digital adjustment of the different input offsets.

APPLICATIONS

- CCD type of systems
- Scanner
- Copier
- Video acquisition.

QUICK REFERENCE DATA

SYMBOL	PARAMETER	CONDITIONS	MIN.	TYP.	MAX.	UNIT
V_{CCA1}	analog supply voltage 1		4.75	5.0	5.25	V
V_{CCA2}	analog supply voltage 2		4.75	5.0	5.25	V
V_{CCD}	digital supply voltage		4.75	5.0	5.25	V
V_{CCO}	TTL output supply voltage		4.75	5.0	5.25	V
I_{CCA}	analog supply current		–	80	–	mA
I_{CCD}	digital supply current		–	30	–	mA
I_{CCO}	TTL output supply current		–	9	–	mA
INL	integral non-linearity	0 to 20 dB gain; ramp input	–	± 0.7	tbF	LSB
DNL	differential non-linearity	0 to 20 dB gain; ramp input	–	± 0.4	tbF	LSB
$f_{clk(max)}$	maximum clock frequency	ADC and DAC	30	–	–	MHz
B	controlled gain amplifier bandwidth		–	100	–	MHz
P_{tot}	total power dissipation		–	600	–	mW

ORDERING INFORMATION

TYPE NUMBER	PACKAGE		
	NAME	DESCRIPTION	VERSION
TDA8785H	QFP44	plastic quad flat package; 44 leads (lead length 1.3 mm); body 10 × 10 × 1.75 mm	SOT307-2

8-bit high-speed analog-to-digital converter with gain and offset controls

TDA8785

BLOCK DIAGRAM

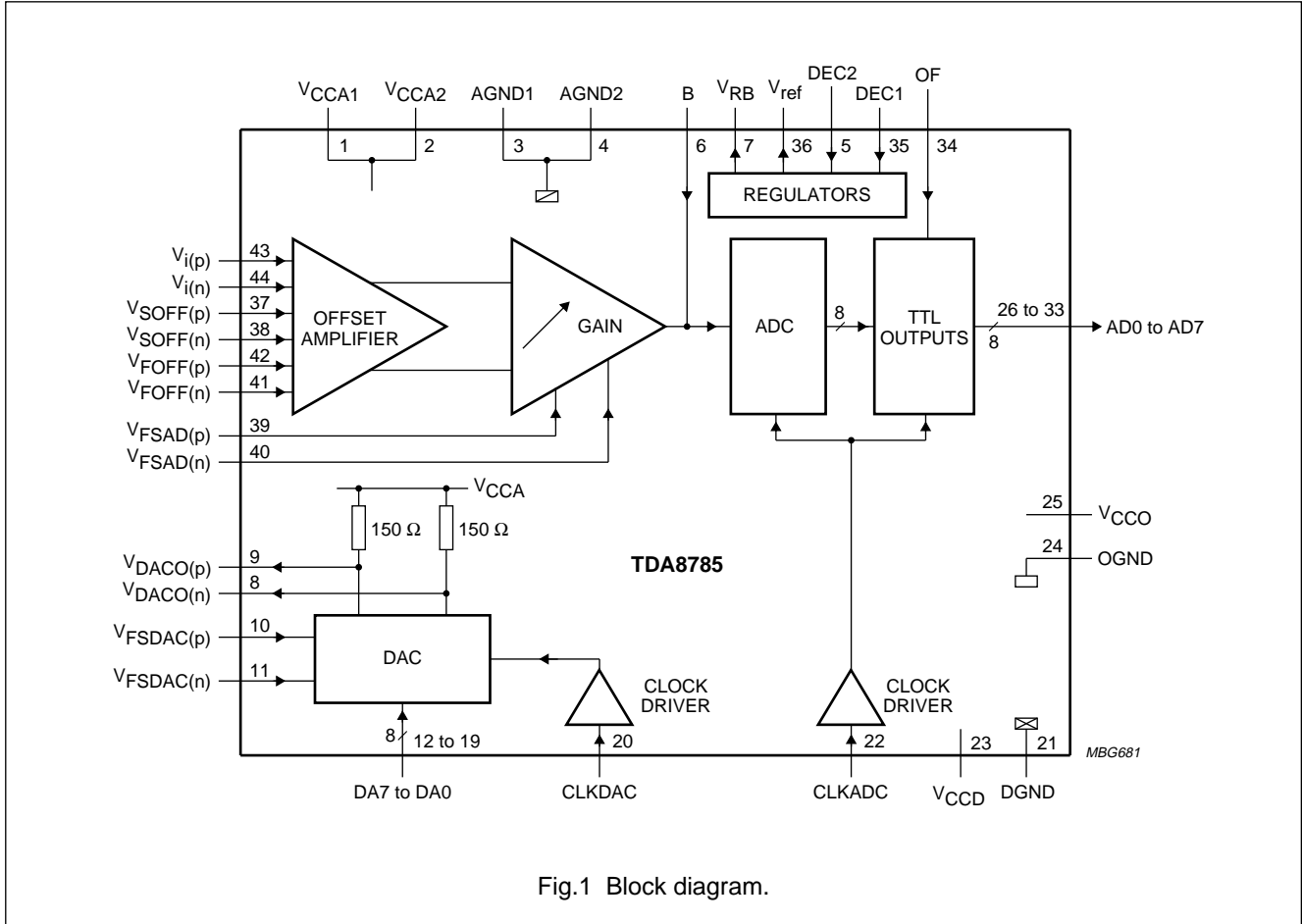

Fig.1 Block diagram.

8-bit high-speed analog-to-digital converter with gain and offset controls

TDA8785

PINNING

SYMBOL	PIN	DESCRIPTION
V _{CCA1}	1	analog supply voltage 1 (+5 V)
V _{CCA2}	2	analog supply voltage 2 (+5 V)
AGND1	3	analog ground 1
AGND2	4	analog ground 2
DEC2	5	decoupling input 2
B	6	bandwidth adjustment node input
V _{RB}	7	ADC reference voltage output bottom (decoupling)
V _{DACO(n)}	8	DAC negative voltage output
V _{DACO(p)}	9	DAC positive voltage output
V _{FSDAC(p)}	10	DAC full-scale positive control voltage input
V _{FSDAC(n)}	11	DAC full-scale negative control voltage input
DA7	12	DAC TTL input; bit 7 (MSB)
DA6	13	DAC TTL input; bit 6
DA5	14	DAC TTL input; bit 5
DA4	15	DAC TTL input; bit 4
DA3	16	DAC TTL input; bit 3
DA2	17	DAC TTL input; bit 2
DA1	18	DAC TTL input; bit 1
DA0	19	DAC TTL input; bit 0 (LSB)
CLKDAC	20	DAC clock input
DGND	21	digital ground
CLKADC	22	ADC clock input
V _{CCD}	23	digital supply voltage (+5 V)

SYMBOL	PIN	DESCRIPTION
OGND	24	output ground
V _{CCO}	25	output supply voltage (+5 V)
AD0	26	output data; bit 0 (LSB)
AD1	27	output data; bit 1
AD2	28	output data; bit 2
AD3	29	output data; bit 3
AD4	30	output data; bit 4
AD5	31	output data; bit 5
AD6	32	output data; bit 6
AD7	33	output data; bit 7 (MSB)
OF	34	output format input
DEC1	35	decoupling input 1
V _{ref}	36	reference voltage output (2.75 V)
V _{SOFF(p)}	37	slow offset amplifier positive voltage input
V _{SOFF(n)}	38	slow offset amplifier negative voltage input
V _{FSAD(p)}	39	gain control positive voltage input
V _{FSAD(n)}	40	gain control negative voltage input
V _{FOFF(n)}	41	fast offset amplifier negative voltage input
V _{FOFF(p)}	42	fast offset amplifier positive voltage input
V _{i(p)}	43	analog positive voltage input
V _{i(n)}	44	analog negative voltage input

8-bit high-speed analog-to-digital converter
with gain and offset controls

TDA8785

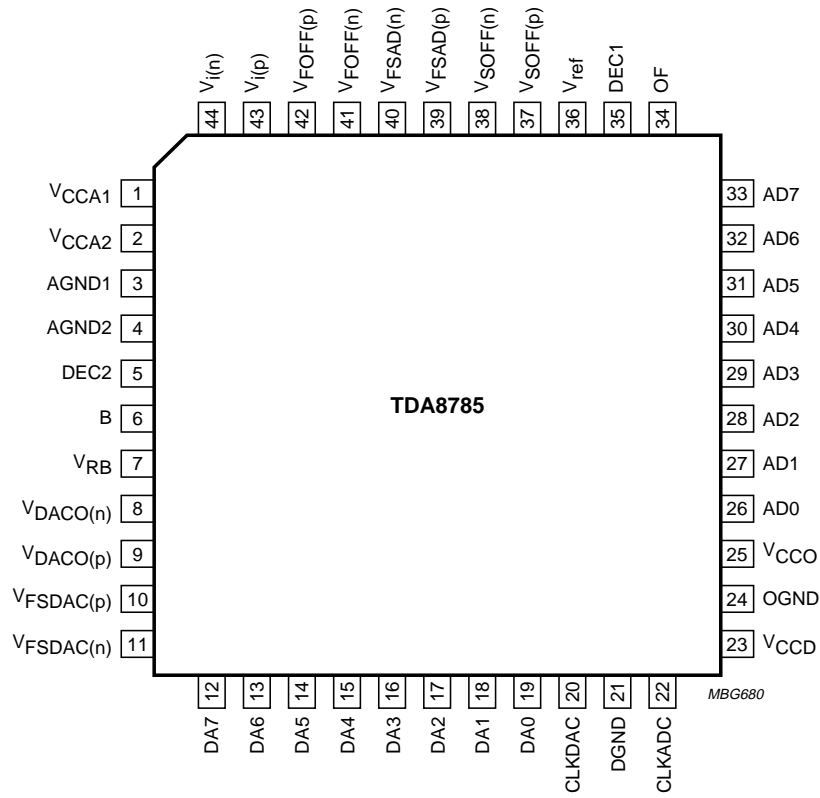

Fig.2 Pin configuration.

8-bit high-speed analog-to-digital converter with gain and offset controls

TDA8785

FUNCTIONAL DESCRIPTION

The TDA8785 is composed of an 8-bit ADC (30 Msps), a wide-band gain amplifier, an input offset amplifier and an 8-bit dynamic adjustment DAC.

Input signal

Two input pins are provided to apply a differential input signal with a wide range (100 to 1000 mV differential). It is also possible to apply a single signal by setting a DC voltage on one of the differential pins and supplying the signal to the other.

Controlled gain amplifier

The gain amplifier is used to adjust the wide input signal range to the fixed ADC input range of 1 V (p-p).

A large gain of 20 dB can be achieved with low-noise behaviour and a large bandwidth of 100 MHz to correctly amplify square type signals with step edges. Using pin 6, it is possible to reduce the internal bandwidth of the gain amplifier via an external capacitor and thus improve its noise behaviour. The gain amplifier is controlled via an external differential voltage (single input can also be applied).

Input offset amplifier and adjustment DAC

The Input offset amplifier contains two different control inputs (which can also be single):

- Slow offset control, for slow variation characteristics (e.g. temperature, supply voltage, etc.)
- Fast offset control, for correction related to the clock rate.

Slow offset control is carried out by an external voltage while fast offset control is digitally carried out via the internal 8-bit DAC with external connections of the respective pins $V_{DACO(n)}$, $V_{DACO(p)}$, $V_{FOFF(n)}$ and $V_{FOFF(p)}$.

The internal 8-bit DAC operates at the ADC clock rate to allow dynamic corrections on the input signal chain based on the signal processing information carried out after the digital conversion. The output voltage amplitude of the DAC can be controlled via a different input voltage (which can also be single) in a range of $\pm 25\%$ with a $150\ \Omega$ DAC output load.

The DAC can also be used for the gain or the slow offset control with some external DC voltage adaptations and can be considered as a separate function of the ADC chain. The DAC can be used independently, for example as a video DAC.

8-bit ADC

The 8-bit ADC converts a signal of 1 V (p-p) from the controlled gain amplifier into an 8-bit coded digital word at a maximum rate of 30 Msps. Its reference voltage is supplied by the general voltage regulator. The output data format can either be binary, two's complement or 3-state by selecting pin OF.

When all the differential inputs on the offset amplifier ($V_{SOFF(p)}$, $V_{SOFF(n)}$, $V_{FOFF(n)}$, $V_{FOFF(p)}$, $V_{i(p)}$ and $V_{i(n)}$) are at 0 V (equivalent to both inputs short-circuited), the output code of the ADC is code 8.

Internal voltage regulator

An internal voltage regulator provides all the references for the different blocks. A stable 2.75 V voltage reference output is provided for use in the application environment. One application is to connect all the slow control inputs ($V_{FSDAC(p)}$, $V_{FSDAC(n)}$, $V_{SOFF(p)}$, $V_{SOFF(n)}$, $V_{FSAD(p)}$ and $V_{FSAD(n)}$) to this reference, either to their two differential inputs to get the nominal settings or to one of the differential inputs to have easy single-input control.

All these control inputs have the same control range.

8-bit high-speed analog-to-digital converter with gain and offset controls

TDA8785

LIMITING VALUES

In accordance with the Absolute Maximum Rating System (IEC 134).

SYMBOL	PARAMETER	CONDITIONS	MIN.	MAX.	UNIT
V_{CCA}	analog supply voltage		-0.3	+7.0	V
V_{CCD}	digital supply voltage		-0.3	+7.0	V
V_{CCO}	output supply voltage		-0.3	+7.0	V
ΔV_{CC}	supply voltage difference between V_{CCA} and V_{CCD}		-1.0	+1.0	V
	V_{CCD} and V_{CCO}		-1.0	+1.0	V
	V_{CCA} and V_{CCO}		-1.0	+1.0	V
V_I	input voltage	referenced to AGND	-0.3	+7.0	V
$V_{clk(p-p)}$	clock input voltage for switching (peak-to-peak value)	referenced to DGND	-	V_{CCD}	V
I_O	output current		-	6	mA
T_{stg}	storage temperature		-55	+150	°C
T_{amb}	operating ambient temperature		0	70	°C
T_j	junction temperature		-	150	°C

THERMAL CHARACTERISTICS

SYMBOL	PARAMETER	VALUE	UNIT
$R_{th\ j-a}$	thermal resistance from junction to ambient in free air	75	K/W

8-bit high-speed analog-to-digital converter with gain and offset controls

TDA8785

CHARACTERISTICS

$V_{CCA1} = V_{CCA2} = V_{CCD} = V_{CCO} = 4.75$ to 5.25 V; AGND, DGND and OGND short-circuited together;
 V_{CCA} to $V_{CCD} = V_{CCD}$ to $V_{CCO} = V_{CCA}$ to $V_{CCO} = -0.25$ to $+0.25$ V; $T_{amb} = 0$ to 70 °C;
 typical values measured at $V_{CCA} = V_{CCD} = V_{CCO} = 5$ V and $T_{amb} = 25$ °C; unless otherwise specified.

SYMBOL	PARAMETER	CONDITIONS	MIN.	TYP.	MAX.	UNIT
Supplies						
V_{CCA1}	analog supply voltage 1		4.75	5.0	5.25	V
V_{CCA2}	analog supply voltage 2		4.75	5.0	5.25	V
V_{CCD}	digital supply voltage		4.75	5.0	5.25	V
V_{CCO}	TTL output supply voltage		4.75	5.0	5.25	V
I_{CCA}	analog supply current		–	80	–	mA
I_{CCD}	digital supply current		–	30	–	mA
I_{CCO}	TTL output supply current		–	9	–	mA
Reference voltages (pins V_{ref} and V_{RB})						
V_{ref}	output reference voltage		2.60	2.75	2.90	V
V_{line}	line regulation voltage	$V_{CCA} = 4.75$ to 5.25 V	–	4	–	mV
I_{LO}	output load current		–1	–	–	mA
V_{RB}	reference voltage output bottom (decoupling)		–	$V_{CCA} - 2.5$	–	V
V_{osB}	offset voltage bottom	code 0 – V_{RB}	–	250	–	mV
ΔV_{ADC}	ADC reference voltage difference	between code 0 and 255	–	1	–	V
Analog inputs (pins $V_{I(p)}$ and $V_{I(n)}$); see Table 1						
$V_{i(p-p)}$	differential input voltage $V_{i(p)} - V_{i(n)}$ (peak-to-peak value)	0 dB gain	–	1000	–	mV
		20 dB gain	–	100	–	mV
V_I	DC input voltage		–	3.0	–	V
I_i	input current		–	10	–	μ A
Z_i	input impedance		–	20	–	k Ω
C_i	input capacitance		–	1	–	pF
Fast amplifier inputs (pins $V_{FOFF(p)}$ and $V_{FOFF(n)}$); DC parameters						
$V_{FOFF(p)}$	input voltage	0 dB gain	–	500	–	mV
		20 dB gain	–	50	–	mV
$V_{FOFF(n)}$	input voltage	0 dB gain	–	500	–	mV
		20 dB gain	–	50	–	mV
V_I	DC input voltage		–	$V_{CCA} - 0.25$	–	V
I_i	input current		–	10	–	μ A
Z_i	input impedance		–	20	–	k Ω
C_i	input capacitance		–	1	–	pF

8-bit high-speed analog-to-digital converter with gain and offset controls

TDA8785

SYMBOL	PARAMETER	CONDITIONS	MIN.	TYP.	MAX.	UNIT
Slow offset amplifier inputs (pins $V_{SOFF(p)}$ and $V_{SOFF(n)}$) gain amplifier at 0 dB; note 1						
V_{os}	offset voltage at ADC input	$V_{SOFF(p)} = 2\text{ V};$ $V_{SOFF(n)} = 2.75\text{ V}$	–	–0.25	–	V
		$V_{SOFF(p)} = 2.75\text{ V};$ $V_{SOFF(n)} = 2.75\text{ V}$	–	0	–	V
		$V_{SOFF(p)} = 3.5\text{ V};$ $V_{SOFF(n)} = 2.75\text{ V}$	–	+0.25	–	V
I_i	input current		–	10	–	μA
Offset reference code; $T_{amb} = 25\text{ }^\circ\text{C}$						
OFSRE	offset reference (ADC output code)	$V_{i(p)} = V_{i(n)};$	–	8	–	code
OFSER	offset reference error on code 8	$V_{FOFF(p)} = V_{FOFF(n)};$ $V_{SOFF(p)} = V_{SOFF(n)};$ amplifier gain set at 0 dB	tbf	0	tbf	code
Gain control inputs (pins $V_{FSAD(p)}$ and $V_{FSAD(n)}$); see Fig.7						
$G_{v(min)}$	minimum voltage gain	$V_{FSAD(p)} = 2\text{ V};$ $V_{FSAD(n)} = 2.75\text{ V}$	–	–	0	dB
$G_{v(max)}$	maximum voltage gain	$V_{FSAD(p)} = 3.5\text{ V};$ $V_{FSAD(n)} = 2.75\text{ V}$	20	–	–	dB
I_i	input current		–	10	–	μA
DAC full-scale control inputs (pins $V_{FSDAC(p)}$ and $V_{FSDAC(n)}$) 150 Ω output load on pins $V_{DACO(p)}$ and $V_{DACO(n)}$; see Table 3						
$V_{DACO(n)}$	DAC output voltage (pin 8)	code 0 at DAC inputs	–	V_{CCA}	–	V
		code 255 at DAC inputs; $V_{FSDAC(p)} = 2\text{ V};$ $V_{FSDAC(n)} = 2.75\text{ V}$	–	$V_{CCA} - 0.4$	–	V
		code 255 at DAC inputs; $V_{FSDAC(p)} = 2.75\text{ V};$ $V_{FSDAC(n)} = 2.75\text{ V}$	–	$V_{CCA} - 0.5$	–	V
		code 255 at DAC inputs; $V_{FSDAC(p)} = 3.5\text{ V};$ $V_{FSDAC(n)} = 2.75\text{ V}$	–	$V_{CCA} - 0.6$	–	V
I_i	input current		–	2	–	μA
Bandwidth adjustment node input (pin B); see Fig.6						
Z_i	input impedance		–	500	–	Ω
8-bit DAC; $f_{clk} = 30\text{ MHz}$, ramp input; $T_{amb} = 25\text{ }^\circ\text{C}$						
Z_o	output impedance		–	150	–	Ω
INL	integral non-linearity		–	± 0.4	tbf	LSB
DNL	differential non-linearity		–	± 0.4	tbf	LSB

8-bit high-speed analog-to-digital converter with gain and offset controls

TDA8785

SYMBOL	PARAMETER	CONDITIONS	MIN.	TYP.	MAX.	UNIT
Digital inputs (pins CLKDAC, CLKADC and DA7 to DA0)						
V _{IL}	LOW level input voltage		0	–	0.8	V
V _{IH}	HIGH level input voltage		2.0	–	V _{CCD}	V
I _{IL}	LOW level input current	V _{clk} = 0.4 V	–400	–	–	μA
I _{IH}	HIGH level input current	V _{clk} = 2.7 V	–	–	100	μA
Z _i	input impedance	f _{clk} = 10 MHz	–	4	–	kΩ
C _i	input capacitance	f _{clk} = 10 MHz	–	4.5	–	pF
ADC output format (pin OF); see Table 2						
V _{IL}	LOW level input voltage		0	–	0.2	V
V _{IH}	HIGH level input voltage		2.6	–	V _{CCD}	V
V _I	input voltage in high impedance state		–	1.15	–	V
I _{IL}	LOW level input current	V _{clk} = 0.4 V	–370	–300	–	μA
I _{IH}	HIGH level input current	V _{clk} = 2.7 V	–	300	450	μA
ADC digital outputs						
V _{OL}	LOW level output voltage	I _{OL} = 2 mA	0	–	0.6	V
V _{OH}	HIGH level output voltage	I _{OH} = –0.4 mA	2.4	–	V _{CCO}	V
ADC and DAC switching; see Fig.4						
f _{clk(max)}	maximum clock frequency	note 2	30	–	–	MHz
t _{CPH}	clock pulse width HIGH		12	–	–	ns
t _{CPL}	clock pulse width LOW		12	–	–	ns
Analog processing; note 3						
INL	integral non-linearity	ramp input (full scale); 0 to 20 dB gain	–	±0.7	tbf	LSB
DNL	differential non-linearity	ramp input (full scale); 0 to 20 dB gain	–	±0.4	tbf	LSB
S/N	signal-to-noise ratio (without harmonics)	f _i = 4.43 MHz 0 dB gain 10 dB gain 20 dB gain	–	47 45 43	–	dB dB dB
B	bandwidth	–3 dB	–	100	–	MHz
t _s	settling time	note 4	–	2	–	code

8-bit high-speed analog-to-digital converter with gain and offset controls

TDA8785

SYMBOL	PARAMETER	CONDITIONS	MIN.	TYP.	MAX.	UNIT
Timing						
ADC DIGITAL OUTPUTS ($C_L = 15$ pF)						
t_{ds}	sampling delay time		–	1.5	–	ns
t_h	output hold time		7	–	–	ns
t_d	output delay time		–	–	16	ns
DAC OUTPUTS (PINS $V_{DACO(p)}$ AND $V_{DACO(n)}$)						
$t_{SU; DAT}$	data set-up time	note 5	–0.3	–	–	ns
$t_{HD; DAT}$	data hold time	note 5	–	–	2	ns
t_s	DAC settling time (1% accuracy)	$R_L = 150 \Omega$; $C_L = 15$ pF	–	8	–	ns
3-STATE OUTPUT DELAY TIMES (see Fig.5)						
t_{dZH}	enable HIGH		–	12	14	ns
t_{dZL}	enable LOW		–	10	12	ns
t_{dHZ}	disable HIGH		–	58	62	ns
t_{dLZ}	disable LOW		–	70	74	ns

Notes

- V_{os} is proportional to the amplifier gain. For instance, V_{os} at 20 dB is the one indicated at 0 dB multiplied by 10.
- It is recommended that the rise and fall times of the clock are >1 ns. In addition a good layout for the digital and analog grounds is recommended.
- Analog processing from signal inputs or fast offset amplifier inputs to ADC digital output; $f_{clk} = 30$ MHz; no external filtering on pin 6 (B).
- Settling time is the number of code variations at the ADC output, after one clock period settling. A full-scale jump is applied at the DAC inputs, with the DAC output (square signal) connected to the fast offset amplifier input. ADC and DAC clock signals (CLKADC and CLKDAC) are in phase.
- The data set-up time ($t_{SU; DAT}$) is the minimum period preceding the rising edge of the clock, that the input data must be stable in order to be correctly registered. A negative set-up time indicates that the data may be initiated after the rising edge and still be recognized. The data set hold time ($t_{HD; DAT}$) is the minimum period following the rising edge of the clock, that the input data must be stable in order to be correctly registered. A negative hold time indicates that the data may be released prior to the rising edge and still be recognized.

8-bit high-speed analog-to-digital converter with gain and offset controls

TDA8785

Table 1 Output coding and input voltage (typical values; referenced to AGND, $V_{i(p)} - V_{i(n)} = 1$ V (p-p), 0 dB gain, no offset correction)

STEP	$V_{i(p)} - V_{i(n)}$	BINARY OUTPUT BITS								TWO'S COMPLEMENT OUTPUT BITS							
		D7	D6	D5	D4	D3	D2	D1	D0	D7	D6	D5	D4	D3	D2	D1	D0
Underflow	<-0.032	0	0	0	0	0	0	0	0	1	0	0	0	0	0	0	0
0	-0.032	0	0	0	0	0	0	0	0	1	0	0	0	0	0	0	0
1	–	0	0	0	0	0	0	0	1	1	0	0	0	0	0	0	1
.	–
8	0	0	0	0	0	1	0	0	0	1	0	0	0	1	0	0	0
.	–
254	–	1	1	1	1	1	1	1	0	0	1	1	1	1	1	1	0
255	0.968	1	1	1	1	1	1	1	1	0	1	1	1	1	1	1	1
Overflow	>0.968	1	1	1	1	1	1	1	1	0	1	1	1	1	1	1	1

Table 2 OF input coding

OF	AD0 to AD7
0	active, two's complement
1	high impedance
open circuit ⁽¹⁾	active, binary

Note

1. Use $C \geq 10$ pF to DGND.

Table 3 Input coding and DAC output voltages (typical values; referenced to V_{CCA} regardless of the offset voltage);
 $V_{FSDAC(p)} = V_{FSDAC(n)}$

CODE	BINARY INPUT DATA								DAC OUTPUT VOLTAGES (V)			
	DA7	DA6	DA5	DA4	DA3	DA2	DA1	DA0	$Z_L = 10$ k Ω		$Z_L = 150$ Ω	
									$V_{DACO(p)}$	$V_{DACO(n)}$	$V_{DACO(p)}$	$V_{DACO(n)}$
0	0	0	0	0	0	0	0	0	-1.0	0	-0.5	0
1	0	0	0	0	0	0	0	1	–	–	–	–
.
128	1	0	0	0	0	0	0	0	-0.5	-0.5	-0.25	-0.25
.
254	1	1	1	1	1	1	1	0	–	–	–	–
255	1	1	1	1	1	1	1	1	0	-1.0	0	-0.5

8-bit high-speed analog-to-digital converter
with gain and offset controls

TDA8785

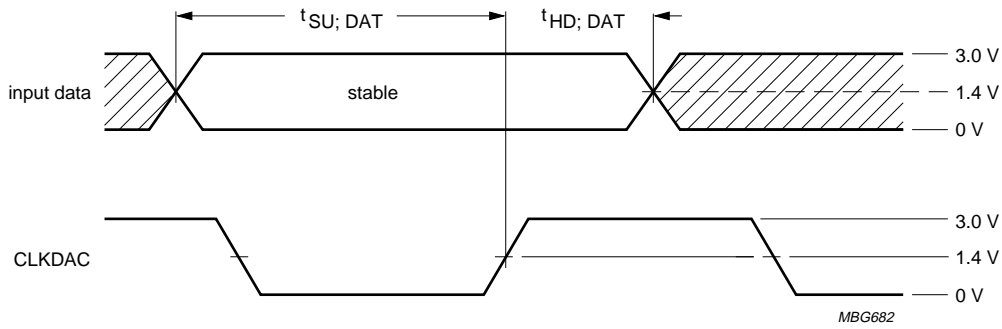

The shaded areas indicate when the input data may change and be correctly registered. Data input update must be completed within 0.3 ns, after the first rising edge of the clock ($t_{SU; DAT}$ is negative; -0.3 ns). Data must be held at least 2 ns after the rising edge ($t_{HD; DAT} = +2$ ns).

Fig.3 Data set-up and hold times (DAC).

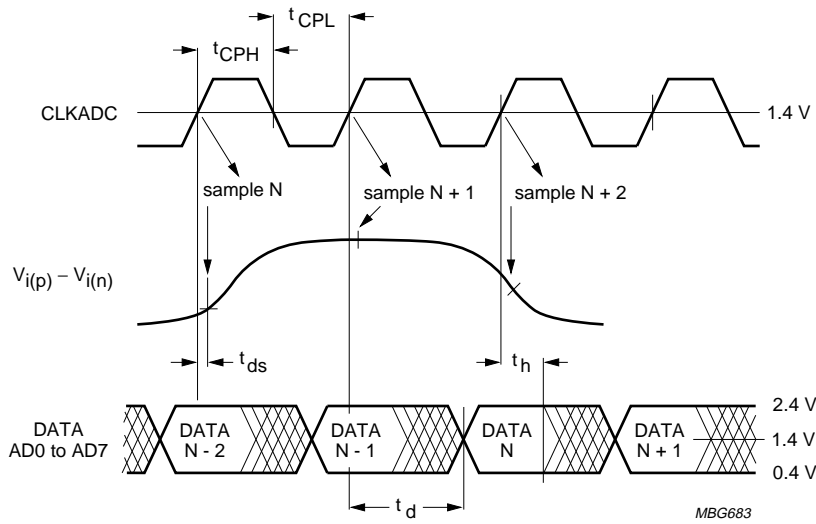

Fig.4 Timing diagram

8-bit high-speed analog-to-digital converter
with gain and offset controls

TDA8785

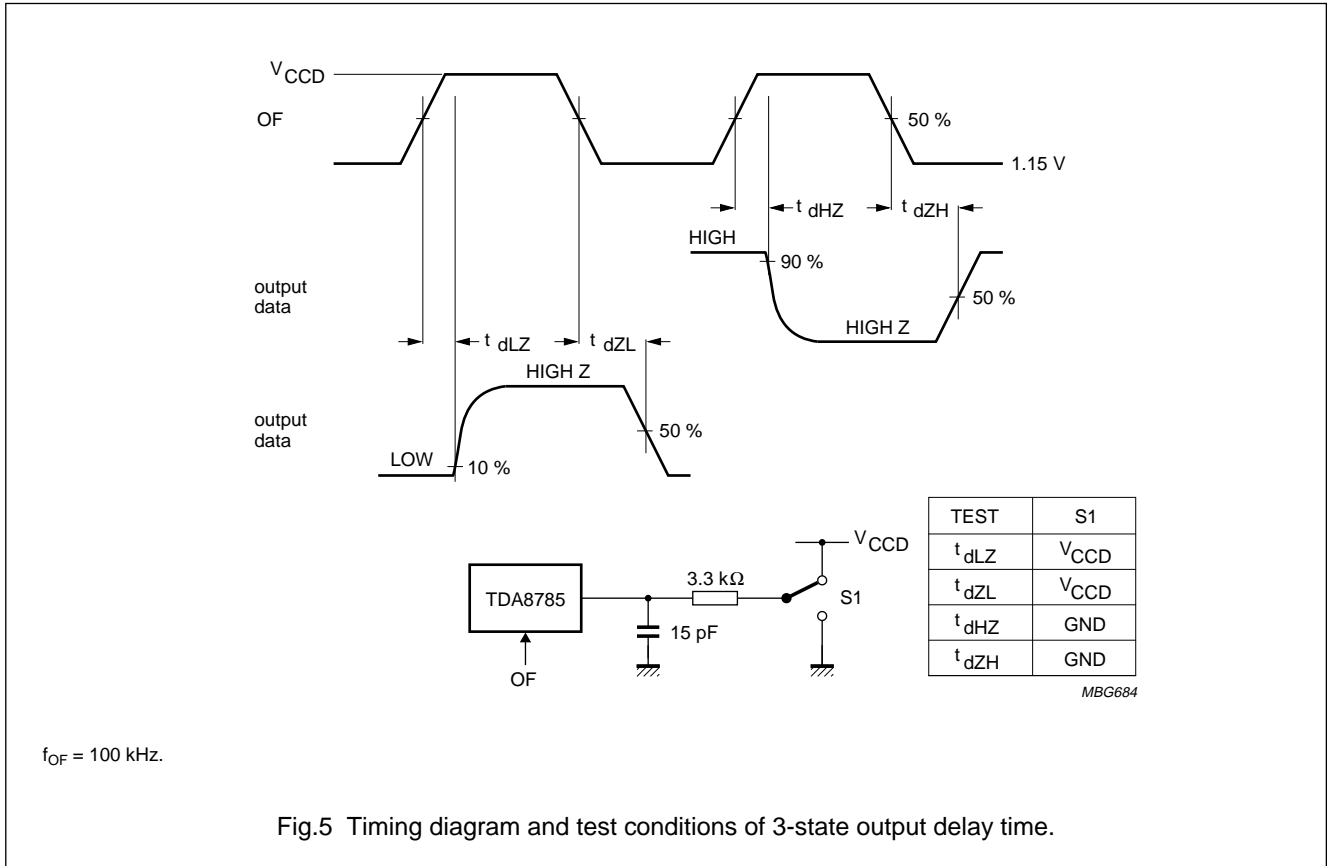
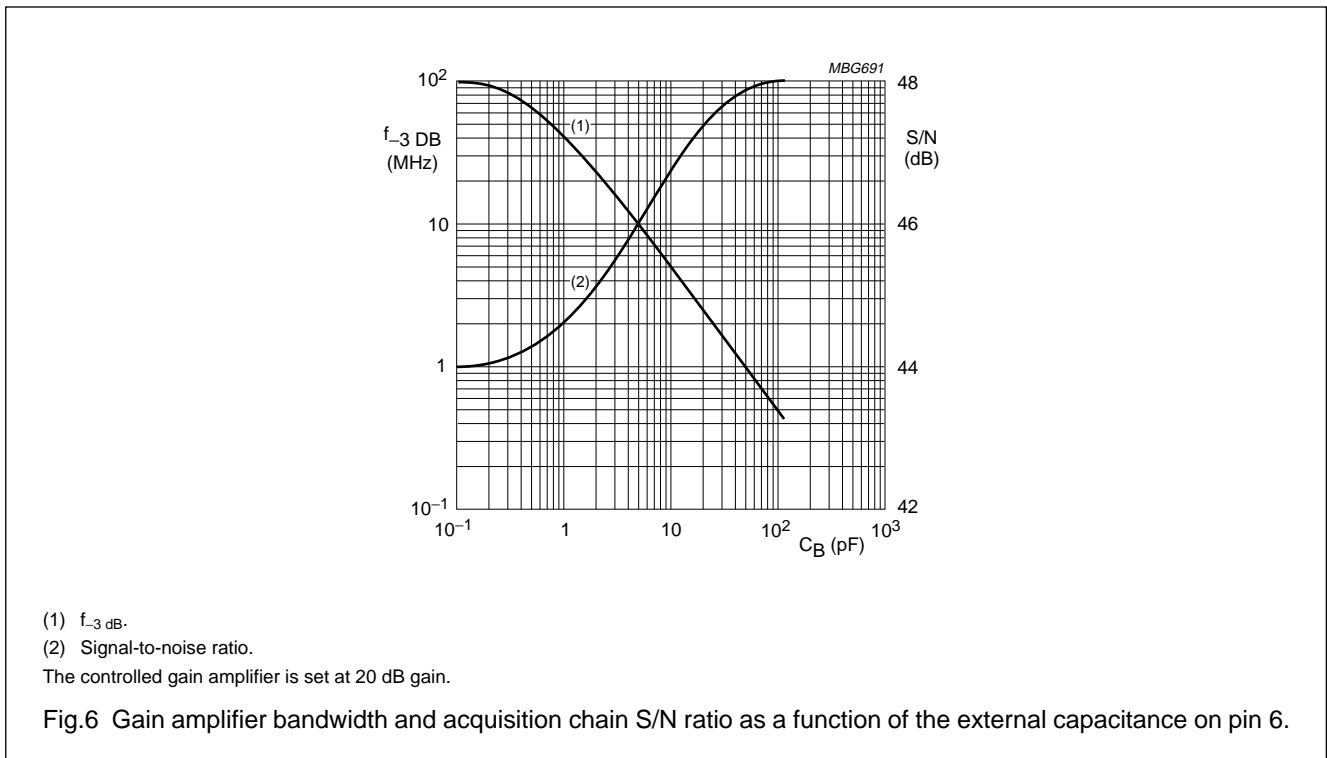

Fig.5 Timing diagram and test conditions of 3-state output delay time.



8-bit high-speed analog-to-digital converter
with gain and offset controls

TDA8785

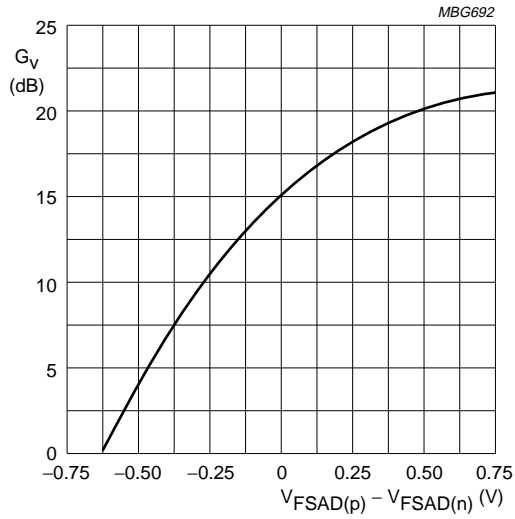
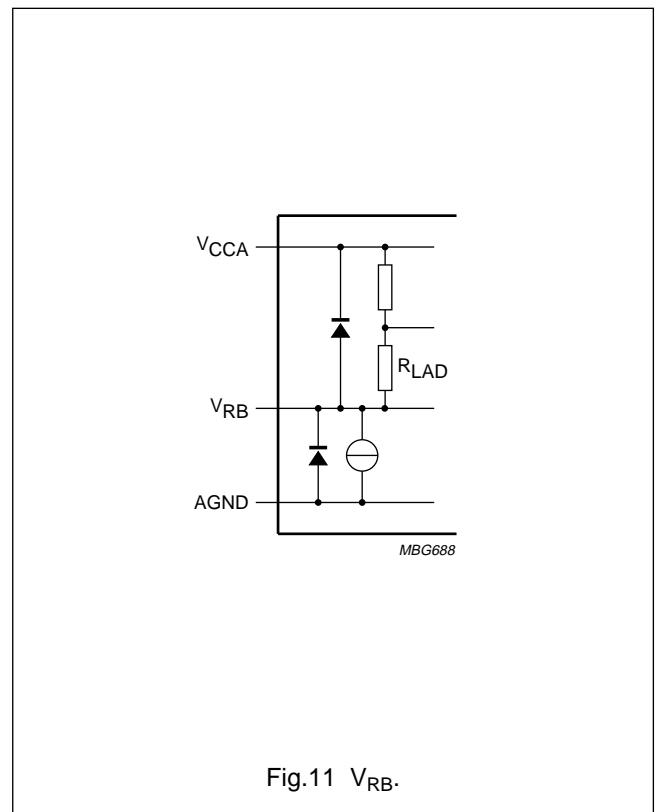
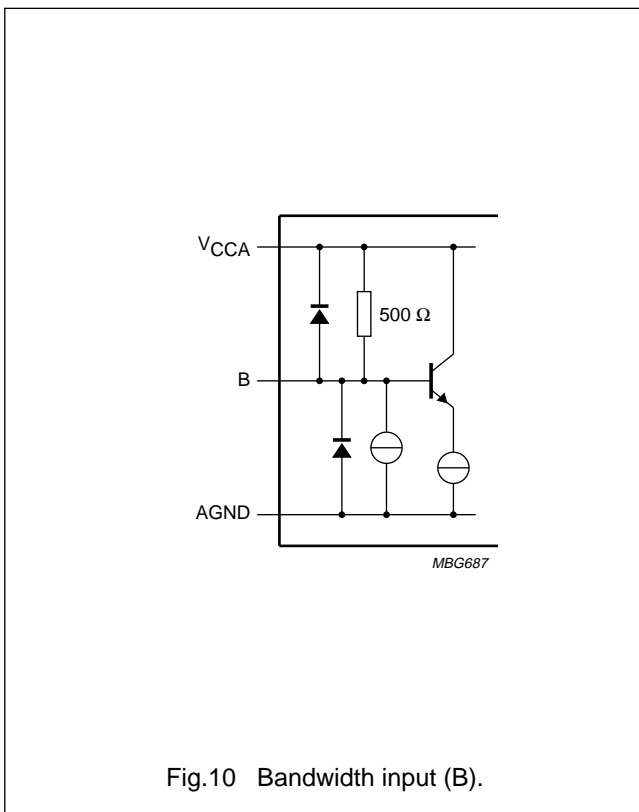
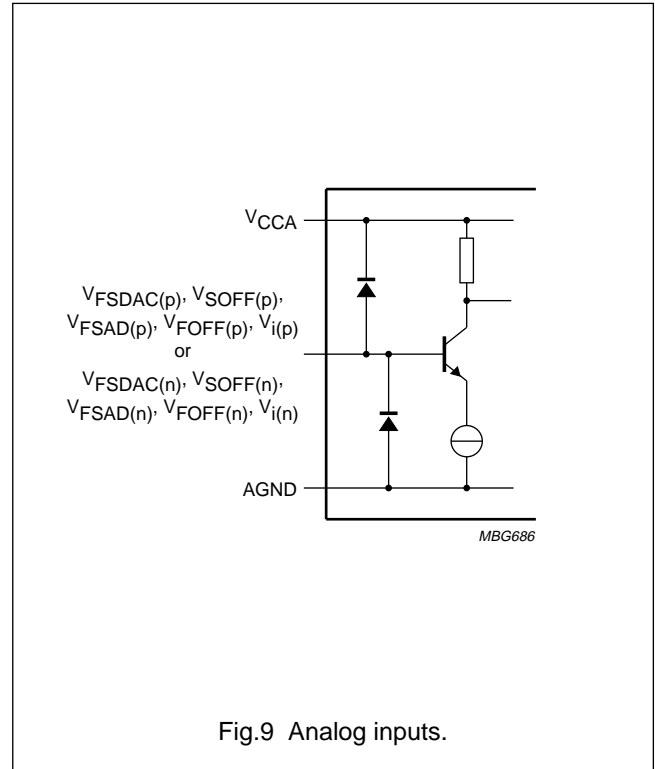
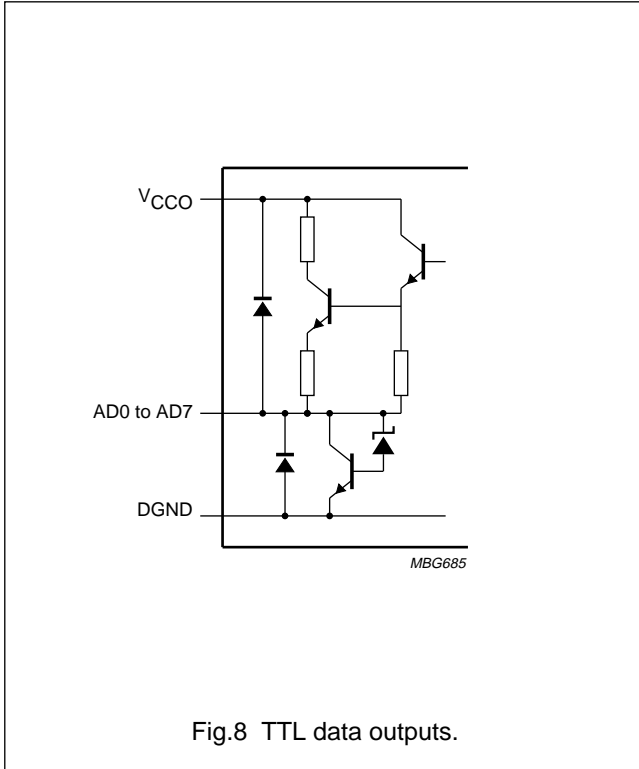

Fig.7 Typical amplifier gain (G_V) as a function of the differential input voltage; $V_{FSAD(p)} - V_{FSAD(n)}$.

8-bit high-speed analog-to-digital converter
with gain and offset controls

TDA8785

INTERNAL PIN CONFIGURATIONS



8-bit high-speed analog-to-digital converter with gain and offset controls

TDA8785

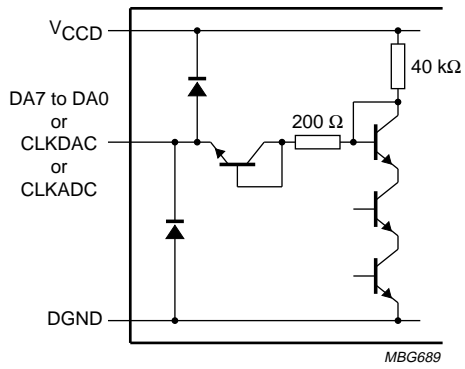

Fig.12 DAC inputs.

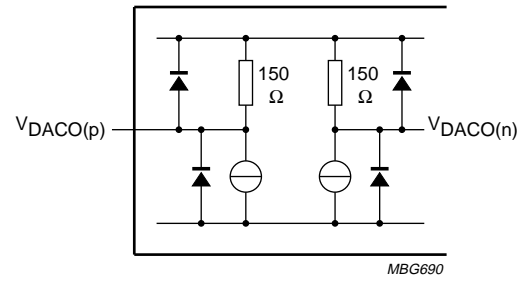

Fig.13 DAC outputs.

8-bit high-speed analog-to-digital converter with gain and offset controls

TDA8785

APPLICATION INFORMATION

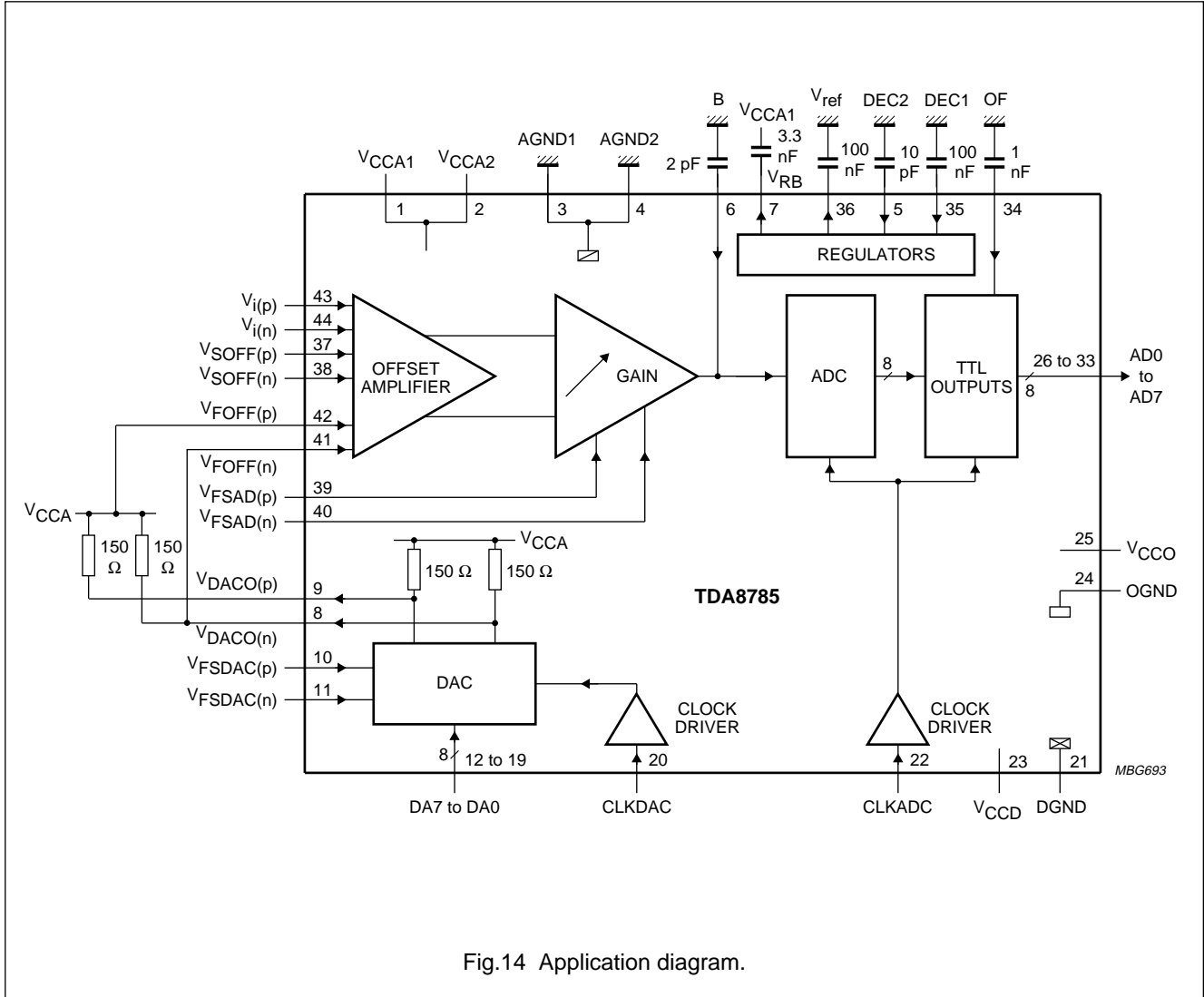

Fig.14 Application diagram.

8-bit high-speed analog-to-digital converter
with gain and offset controls

TDA8785

PACKAGE OUTLINE

QFP44: plastic quad flat package; 44 leads (lead length 1.3 mm); body 10 x 10 x 1.75 mm

SOT307-2

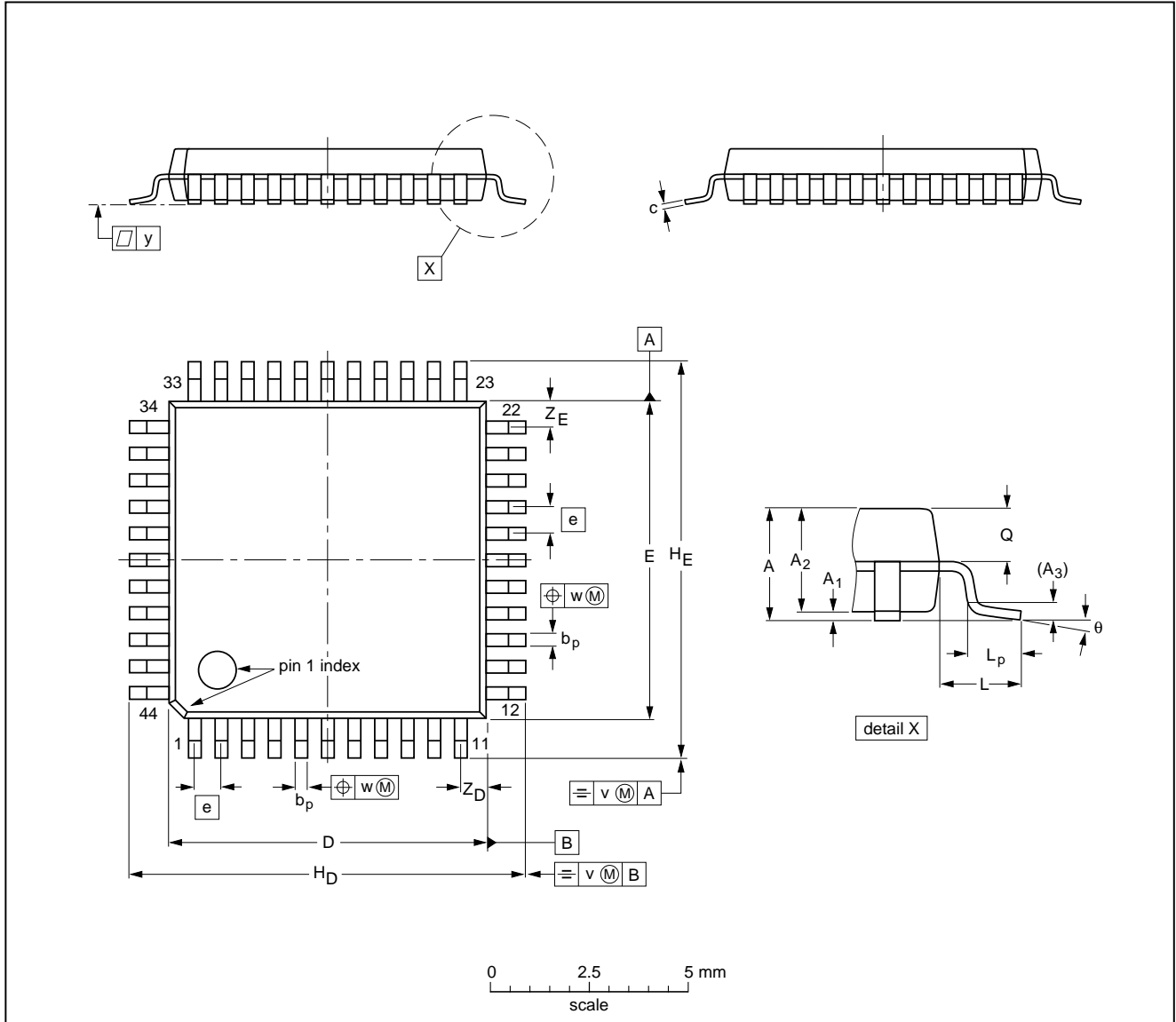

DIMENSIONS (mm are the original dimensions)

UNIT	A max.	A ₁	A ₂	A ₃	b _p	c	D ⁽¹⁾	E ⁽¹⁾	e	H _D	H _E	L	L _p	Q	v	w	y	Z _D ⁽¹⁾	Z _E ⁽¹⁾	θ
mm	2.10	0.25 0.05	1.85 1.65	0.25	0.40 0.20	0.25 0.14	10.1 9.9	10.1 9.9	0.8	12.9 12.3	12.9 12.3	1.3	0.95 0.55	0.85 0.75	0.15	0.15	0.1	1.2 0.8	1.2 0.8	10° 0°

Note

1. Plastic or metal protrusions of 0.25 mm maximum per side are not included.

OUTLINE VERSION	REFERENCES				EUROPEAN PROJECTION	ISSUE DATE
	IEC	JEDEC	EIAJ			
SOT307-2						92-11-17 95-02-04

8-bit high-speed analog-to-digital converter with gain and offset controls

TDA8785

SOLDERING

Introduction

There is no soldering method that is ideal for all IC packages. Wave soldering is often preferred when through-hole and surface mounted components are mixed on one printed-circuit board. However, wave soldering is not always suitable for surface mounted ICs, or for printed-circuits with high population densities. In these situations reflow soldering is often used.

This text gives a very brief insight to a complex technology. A more in-depth account of soldering ICs can be found in our *"IC Package Databook"* (order code 9398 652 90011).

Reflow soldering

Reflow soldering techniques are suitable for all QFP packages.

The choice of heating method may be influenced by larger plastic QFP packages (44 leads, or more). If infrared or vapour phase heating is used and the large packages are not absolutely dry (less than 0.1% moisture content by weight), vaporization of the small amount of moisture in them can cause cracking of the plastic body. For more information, refer to the Drypack chapter in our *"Quality Reference Handbook"* (order code 9397 750 00192).

Reflow soldering requires solder paste (a suspension of fine solder particles, flux and binding agent) to be applied to the printed-circuit board by screen printing, stencilling or pressure-syringe dispensing before package placement.

Several techniques exist for reflowing; for example, thermal conduction by heated belt. Dwell times vary between 50 and 300 seconds depending on heating method. Typical reflow temperatures range from 215 to 250 °C.

Preheating is necessary to dry the paste and evaporate the binding agent. Preheating duration: 45 minutes at 45 °C.

Wave soldering

Wave soldering is **not** recommended for QFP packages. This is because of the likelihood of solder bridging due to closely-spaced leads and the possibility of incomplete solder penetration in multi-lead devices.

If wave soldering cannot be avoided, the following conditions must be observed:

- **A double-wave (a turbulent wave with high upward pressure followed by a smooth laminar wave) soldering technique should be used.**
- **The footprint must be at an angle of 45° to the board direction and must incorporate solder thieves downstream and at the side corners.**

Even with these conditions, do not consider wave soldering the following packages: QFP52 (SOT379-1), QFP100 (SOT317-1), QFP100 (SOT317-2), QFP100 (SOT382-1) or QFP160 (SOT322-1).

During placement and before soldering, the package must be fixed with a droplet of adhesive. The adhesive can be applied by screen printing, pin transfer or syringe dispensing. The package can be soldered after the adhesive is cured.

Maximum permissible solder temperature is 260 °C, and maximum duration of package immersion in solder is 10 seconds, if cooled to less than 150 °C within 6 seconds. Typical dwell time is 4 seconds at 250 °C.

A mildly-activated flux will eliminate the need for removal of corrosive residues in most applications.

Repairing soldered joints

Fix the component by first soldering two diagonally-opposite end leads. Use only a low voltage soldering iron (less than 24 V) applied to the flat part of the lead. Contact time must be limited to 10 seconds at up to 300 °C. When using a dedicated tool, all other leads can be soldered in one operation within 2 to 5 seconds between 270 and 320 °C.

8-bit high-speed analog-to-digital converter with gain and offset controls

TDA8785

DEFINITIONS

Data sheet status	
Objective specification	This data sheet contains target or goal specifications for product development.
Preliminary specification	This data sheet contains preliminary data; supplementary data may be published later.
Product specification	This data sheet contains final product specifications.
Limiting values	
Limiting values given are in accordance with the Absolute Maximum Rating System (IEC 134). Stress above one or more of the limiting values may cause permanent damage to the device. These are stress ratings only and operation of the device at these or at any other conditions above those given in the Characteristics sections of the specification is not implied. Exposure to limiting values for extended periods may affect device reliability.	
Application information	
Where application information is given, it is advisory and does not form part of the specification.	

LIFE SUPPORT APPLICATIONS

These products are not designed for use in life support appliances, devices, or systems where malfunction of these products can reasonably be expected to result in personal injury. Philips customers using or selling these products for use in such applications do so at their own risk and agree to fully indemnify Philips for any damages resulting from such improper use or sale.