

General Description

VMR6512 is a highly integrated FM audio signal transmitter module. It integrates advanced digital signal processor (DSP), frequency synthesizer, RF power amplifier and matching network. So it can realize FM audio modulation without any external components. VMR6512 can also achieve broadcast quality sound by using digital pre-emphasis, digital filtering, automatic gain

control and digital frequency control technologies.

Features

- Broadcast sound
- Fully integrated encapsulation, it can work without any external components.
- Audio frequency processed by DSP, guaranteeing high quality sound
- Using frequency synthetic technology, high stability of oscillation frequency
- Output power adjustable. (up to 115dBuV)
- Frequency range is 88.0MHz to 108.0MHz, low-end can be extended to 76.0MHz upon request.
- It can input analog audio or digital audio
- It possesses external UART interface and can be easily controlled by external CPU or PC machines
- It provides frequency setting UP / DOWN input and can be used independently.

Application

- Hi-Fi wireless headphone
- MP3 audio transponder in the car
- Wireless microphones
- Conference Broadcasting System
- Music in the building
- Music in the park
- Accessories of audio-visual entertainment equipment
- Radio station in campus

Applicative Circuit

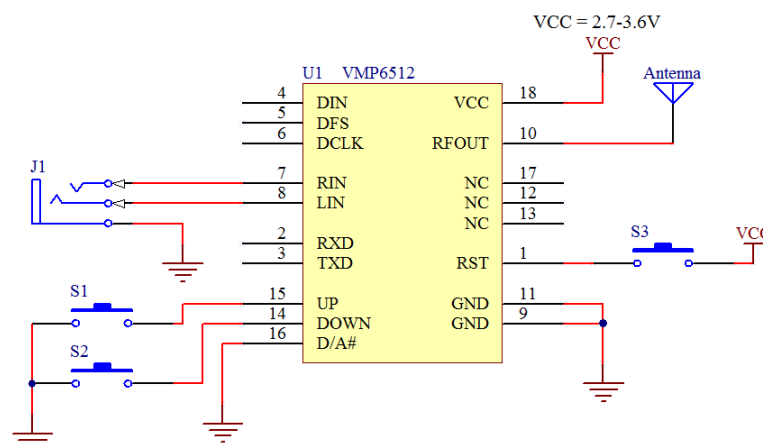

Pin Description

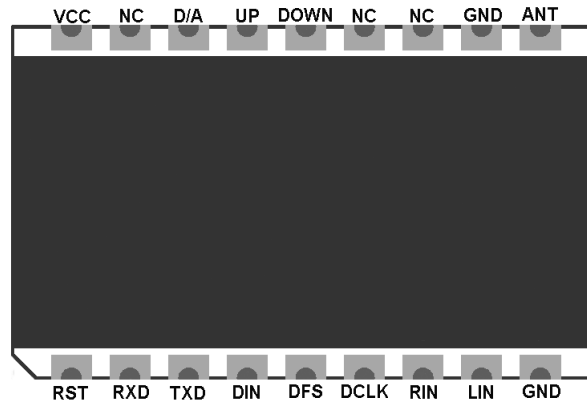

Pin No.	Name	Description
1	RST	Reset, reset the module with high PWL
2	RXD	control serial input RX
3	TXD	control serial output TX
4	DIN	digital audio data input
5	DFS	digital audio frame synchronized signal input
6	DCLK	digital audio clock signal input
7	RIN	analog audio input on the right
8	LIN	Analog audio input on the left
9	GND	Ground
10	RFOUT	RF output
11	GND	Ground
12	NC	-
13	NC	-
14	DOWN	Frequency reduction input, each low PWL impulse output frequency decreases 0.1MHz, continuous low PWL repeats every 0.3 seconds.
15	UP	Frequency increasing input, each low PWL impulse output frequency increases 0.1MHz, continuous low frequency every 0.5 seconds.
16	D/A#	Audio input digit / analog selection
17	NC	-
18	VCC	Power input ,2.7-3 .3 V

Electrical parameters

Symbol	Parameter	Value
Vcc	supply voltage	2.7-3.6V
Ic	Operating Current (max)	32mA
Fr	FM transmission frequency	88.0-108.0MHz
Fon	power default frequency	100.0MHz

Pmax	maximum RF power	115dBuV
Ss	Stereo Separation	35dB
SCR	付载频抑制	50dB
Afl	Filter-3dB low-end	25Hz
Afh	Filter-3dB high-end	16kHz
Fm	Modulate frequency offset	68.25KHz
Rf	Audio response flatness (30Hz-15KHz)	±1.5dB
Rin	Input impedance	56kOhm
Vain	Audio input amplitude	350mVp-p

Functional Diagram

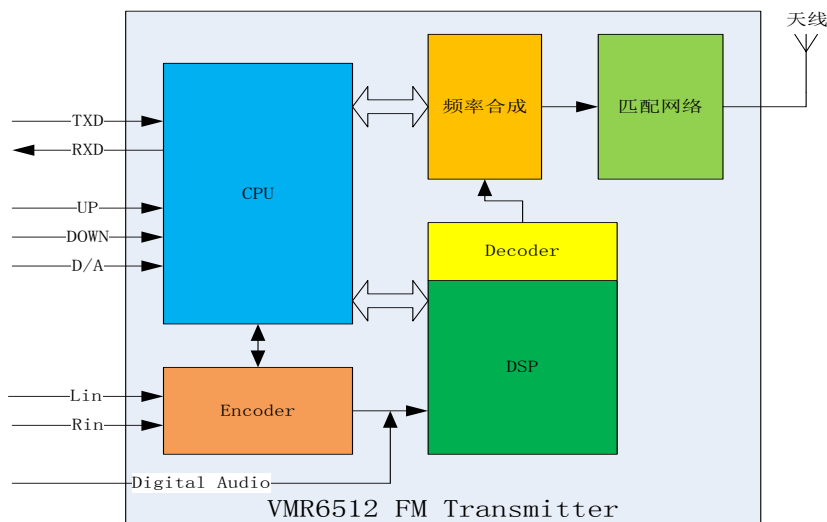

Function

•Reset

Reset pin set to high PWL will reset the what are reseted include the controller, DSP and frequency synthesizer. After reset, the transmission frequency will be 100.0MHz, transmission power will be 115dBuV. The system begins working 160ms after the Reset signal becomes lower.

•Analog audio input Rin, Lin

Rin and Lin is the analog audio signal input pin of a module. There is a capacitor in the pin. So the other external components are not needed. Audio input impedance is approximately 56kΩ, the maximum is 350mVp-p.

•Digital audio input interface

Digital audio input interface is consisted of SCLK, DIN and FS. It can be set to I2S, DSP and Left Justified three different formats through commanding and connected seamlessly with almost all the DSP and Coded.

•UP / DOWN pin

UP and DOWN pins are used to change the operating frequency without the external controller. Each low PWL impulse greater than 0.05 seconds of UP / DOWN pin will make output RF power increase or reduce 0.1MHz. If you stay low PWL, then the operating frequency will change continuously every 0.3 seconds.

•RF output RFout

As the module has internal matching networks, RF output signal pin RFout should be directly connected to the line without any components. It is proposed that antenna should use 1/4 wavelength wire or rod antenna. Certainly you can

use other high-efficiency antenna. The matching impedance of the antenna should be 50Ω.

•Digital / analog input selection D / A

This signal is used to select the audio input manner of the module. digital input is used when it is high PWL, otherwise, analog input will be used.

•Control interface RXD / TXD

Control interface is consisted of RXD and TXD. The used communication protocol is asynchronous serial UART, baud rate is 19200 and the format is 8bits. One start bit, one stop bit, no parity(19200,8,1,0).

External controller controls the the module in the manner of command plus parameters. The command is 1 byte and the parameter is 2 bytes. Therefore, the length of each command string is 3 bytes, as shown below:

Command	parameter byte 1	parameter byte 2
---------	------------------	------------------

After receiving the command, if the module implemented successfully, it will return to 0x80, followed by 2 parameter bytes. If it fails, it will return a byte 0x00.

Command list is as follows:

Command	parameter 1	parameter 2	Description
0x01	D1	D0	Set the operating frequency. Operating frequency $F_o = 10\text{kHz} \times (D1 \times 256 + D0) \text{ Hz.}$ The default value is 0x2710 (100.0MHz) If D1 = D0 = 0x00, then it will return to the current frequency.
0x02	D1	D0	Set the output frequency. Ph should always be 0. Power is decided by P1, ranging from 0 to 115. The unit is dBuV. The default value is 0x73 (115dBuV) When D0 = 0, the part of RF will change into the standby mode, no RF signal input.
0x03	D1	D0	Set the audio interface mode D1 should always be 0. D0 = 0x00: analog audio input (default value) D0 = 0x01: I2S D0 = 0x02: DSP D0 = 0x03: Left Justified Other value: ignored
0x04	D1	D0	Set the audio Pre-emphasis time constant D1 should always be 0 D0 = 0x00: 75μS (America Standard, the default value) D0 = 0x01: 50μS (Europe, Japan Standard) D0 = 0x02: No Pre-emphasis Other value: ignored

Dimension of encapsulation

